

N.T.S.

NOTES:

1. SIGN POSTS AND ANCHORS SHALL BE TELES PAR OR APPROVED EQUAL.
2. SIGN POSTS ARE 10' LONG TYPICAL, BUT DIFFERENT LENGTH MAY BE REQUIRED BASED ON SIGN SIZE AND MUTCD REQUIREMENTS.



CITY of WESTMINSTER
4800 WEST 92ND AVENUE
WESTMINSTER, COLO. 80031

TYPICAL SIGN POST
ANCHOR DETAIL

DATE: JUNE 2019

T1

MATERIAL DATA			FINISH DATA	
COMPONENT	ASTM DESIGNATION	MIN. YIELD (KSI)	SYSTEM:	FINISH PAINT/GALVANIZED (FPGV)
TAPERED TUBES	A595 GR. A OR A572	55	BASE COAT:	HOT-DIP GALVANIZED TO ASTM A123
PLATES	A36	36	PRIM COAT:	NONE
ANCHOR BOLTS	F1554 GR.55	55	FINISH COAT:	TGIC OR URETHANE POLYESTER POWDER
GALVANIZING HARDWARE	F2329		COLOR:	FS 14056 – FEDERAL GREEN
SIGNAL ARM CONN. BOLTS	A325		SPEC:	F-283E
LUM. ARM CONN. BOLTS	SAE GR.5			

DESIGN CRITERIA:

THE SIGNAL MAST ARM TRAFFIC STRUCTURES SHOWN ON THIS DRAWING HAVE BEEN DESIGNED IN ACCORDANCE WITH THE LOADING AND NOMINAL STRENGTH REQUIREMENTS OF THE 2015 AASHTO "LRFD SPECIFICATIONS FOR STRUCTURAL SUPPORTS FOR HIGHWAY SIGNS, LUMINAIRES, AND TRAFFIC SIGNALS, FIRST EDITION" SLTS-1 INCLUDING LATEST INTERIMS. THE WIND LOADS WERE CALCULATED FROM AN ULTIMATE WIND VELOCITY OF 130MPH WITH A MEAN RECURRENCE INTERVAL OF 1700 YEARS AND AN EFFECTIVE PERFORMANCE TESTED MITIGATION DEVICE APPROVED BY CITY OF LAKEWOOD ALLOWING FOR A FATIGUE CATEGORY OF II. THE FATIGUE LOADS WERE CALCULATED ON THE REQUIREMENTS OF SECTION 11 OF THE CODE, AND THE FOLLOWING

DESIGN CONDITIONS:

- STRUCTURES ARE DESIGNED TO RESIST NATURAL WIND GUSTS BASED ON THE YEARLY MEAN WIND VELOCITY OF 11.2 MPH.
- STRUCTURES ARE NOT DESIGNED TO RESIST GALLOPING-INDUCED CYCLIC LOADS DUE TO THE USE OF EFFECTIVE MITIGATION DEVICE.
- STRUCTURES ARE DESIGNED FOR TRUCK-INDUCED GUST LOADS, AS REQUIRED BY THE OWNER OF THE STRUCTURES.



CITY of WESTMINSTER
4800 WEST 92ND AVENUE
WESTMINSTER, COLO. 80031

SIGNAL POLES
DESIGN INFORMATION

DATE: JUNE 2019

T2

LUMINAIRE ARM DATA		
QTY.	ARM SPAN "L" (FT)	RISE HEIGHT "R"
	15.00	3'-0"

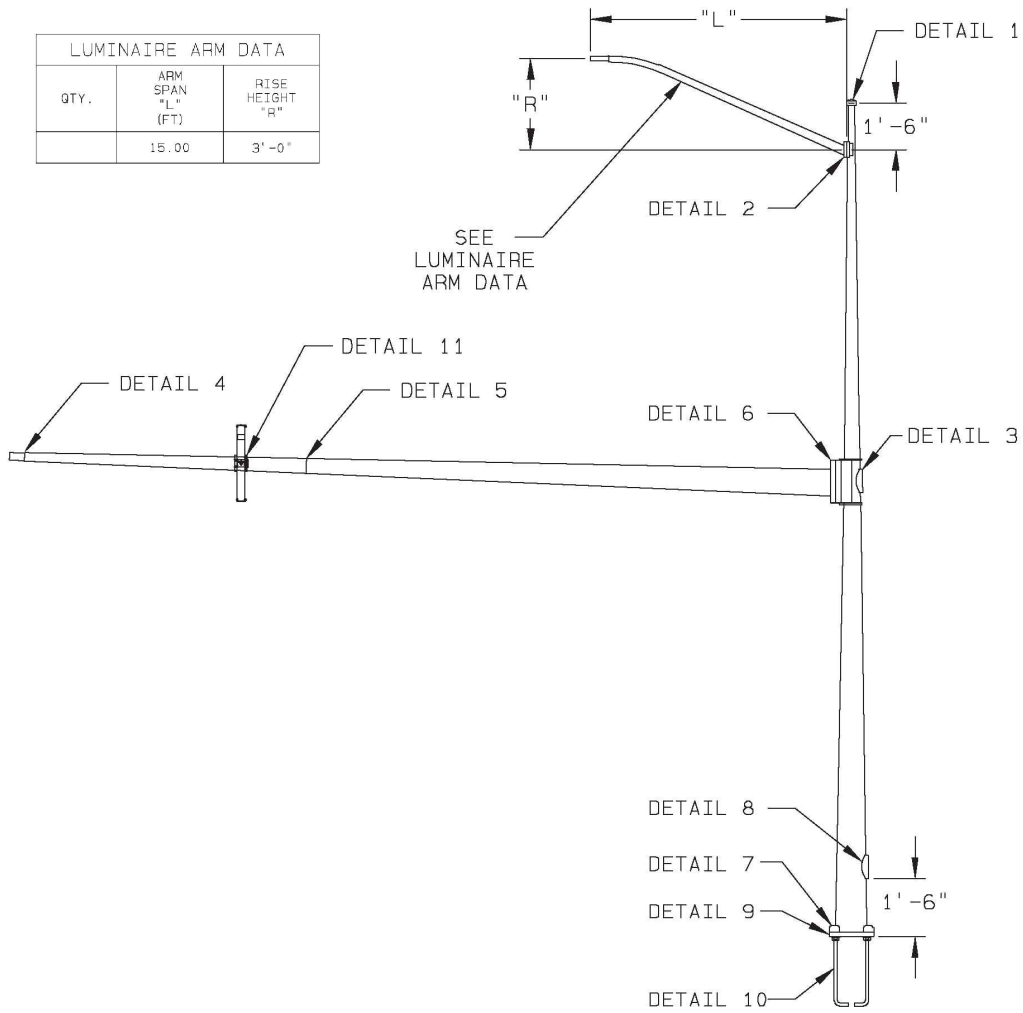

POLE DATA								
QTY.	ITEM	DESIGN NUMBER	SINGLE ARM SPAN (FT)	POLE BASE		ANCHOR BOLT		
				BOLT CIRCLE "Y" (IN)	DIA. "K" (IN)	LENGTH "J" (IN)	HOOK "H" (IN)	THREAD LENGTH "U" (IN)
	LAKWOOD	1	20	19.00	1.50	54.00	6.00	8.00
	LAKWOOD	1	25	19.00	1.50	54.00	6.00	8.00
	LAKWOOD	1	30	19.00	1.50	54.00	6.00	8.00
	LAKWOOD	2	35	20.00	1.75	84.00	6.00	8.00
	LAKWOOD	2	40	20.00	1.75	84.00	6.00	8.00
	LAKWOOD	2	45	20.00	1.75	84.00	6.00	8.00
	LAKWOOD	3	50	22.00	2.00	84.00	6.00	10.00
	LAKWOOD	3	55	22.00	2.00	84.00	6.00	10.00
	LAKWOOD	3	60	22.00	2.00	84.00	6.00	10.00
	LAKWOOD	4	65	23.50	2.25	89.00	7.00	12.00
	LAKWOOD	4	70	23.50	2.25	89.00	7.00	12.00



CITY of WESTMINSTER
4800 WEST 92ND AVENUE
WESTMINSTER, COLO. 80031

SIGNAL POLES
GENERAL LAYOUT

DATE: JUNE 2019

T3

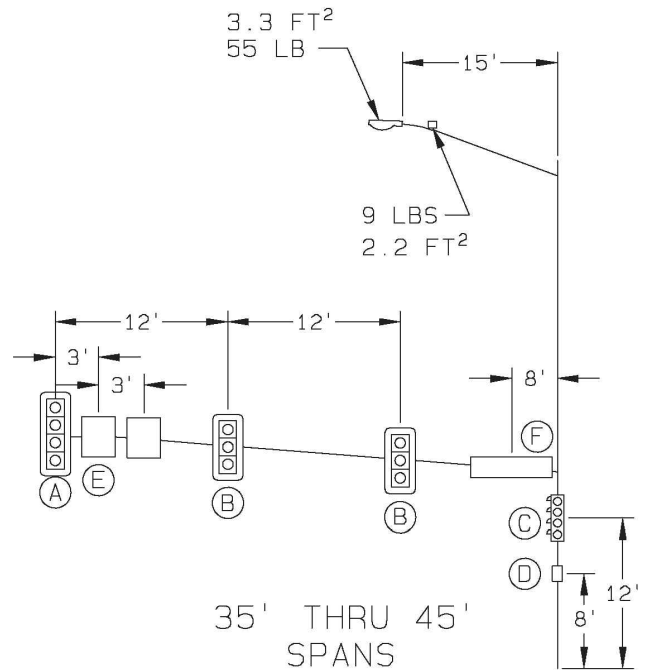
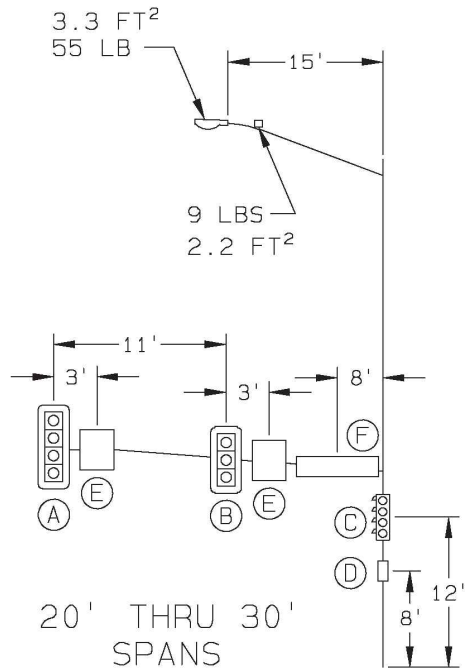

DEVICE	DESCRIPTION	PROJ. AREA (FT ²)	WEIGHT (LBS)
(A)	12"-4 SEC. SIGNAL WITH BACKPLATE	11.60	65
(B)	12"-3 SEC. SIGNAL WITH BACKPLATE	8.67	38
(C)	DUAL-12"-4 SEC. SIGNAL NO BACKPLATE (VERTICAL)	5.44	60
(D)	DUAL-16"-PEDESTRIAN SIGNAL	8.00	80
(E)	30" X 36" REGULATORY SIGN	7.50	25
(F)	18" X 84" STREET NAME SIGN	10.50	32
(G)	TR1 MITIGATOR DEVICE	1.20	38



CITY of WESTMINSTER
 4800 WEST 92ND AVENUE
 WESTMINSTER, COLO. 80031

**SIGNAL POLES
 MAXIMUM LOADING INFORMATION**

DATE: JUNE 2019

T4

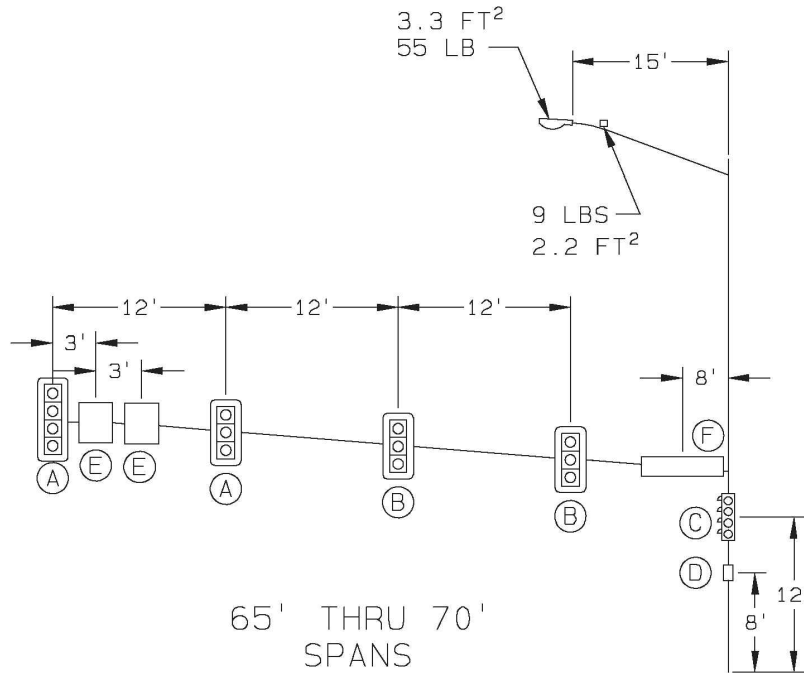
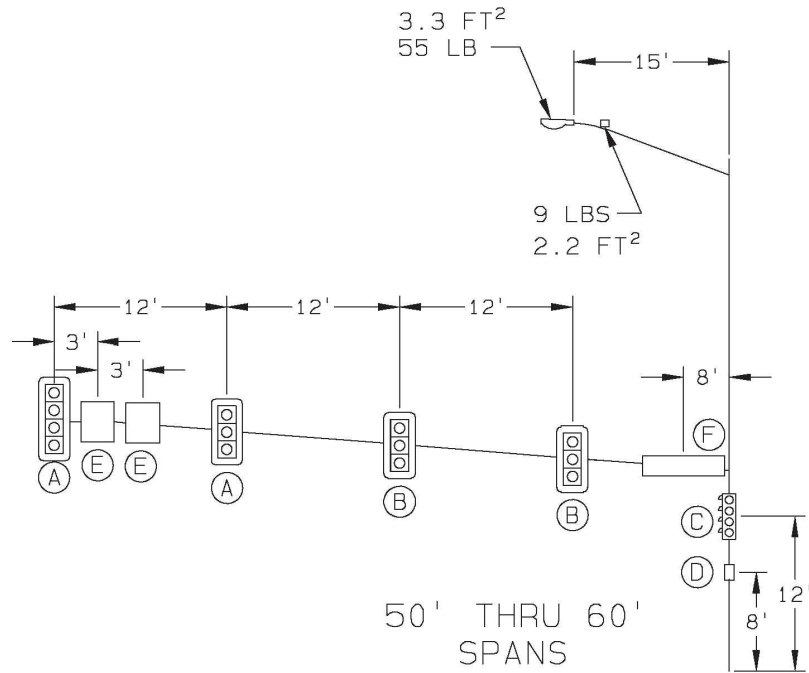

DEVICE	DESCRIPTION	PROJ. AREA (FT ²)	WEIGHT (LBS)
(A)	12"-4 SEC. SIGNAL WITH BACKPLATE	11.60	65
(B)	12"-3 SEC. SIGNAL WITH BACKPLATE	8.67	38
(C)	DUAL-12"-4 SEC. SIGNAL NO BACKPLATE (VERTICAL)	5.44	60
(D)	DUAL-16"-PEDESTRIAN SIGNAL	8.00	80
(E)	30" X 36" REGULATORY SIGN	7.50	25
(F)	18" X 84" STREET NAME SIGN	10.50	32
(G)	TRI MITIGATOR DEVICE	1.20	38



CITY of WESTMINSTER
 4800 WEST 92ND AVENUE
 WESTMINSTER, COLO. 80031

SIGNAL POLES
 MAXIMUM LOADING INFORMATION

DATE: JUNE 2019

T5

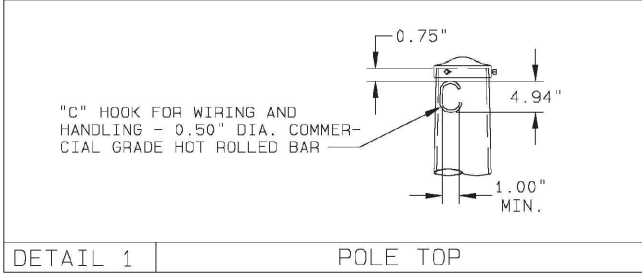

DETAIL 1 | POLE TOP

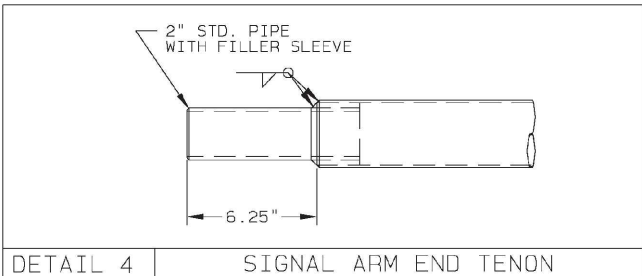

DETAIL 4 | SIGNAL ARM END TENON

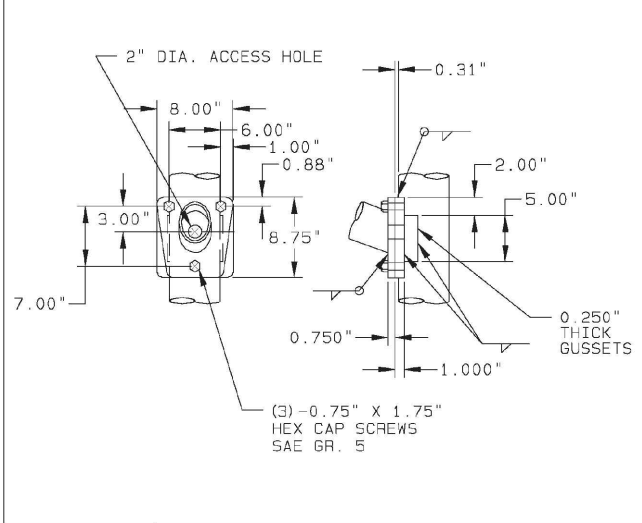

DETAIL 2 | LUMINAIRE ARM ATTACHMENT

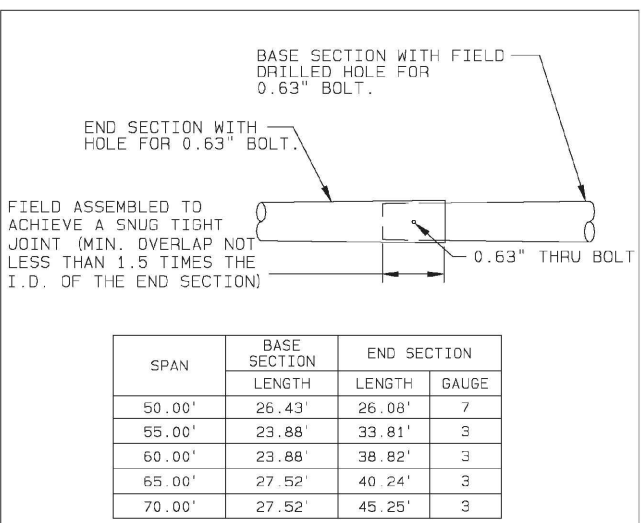

DETAIL 5 | SIGNAL ARM SLIP JOINT

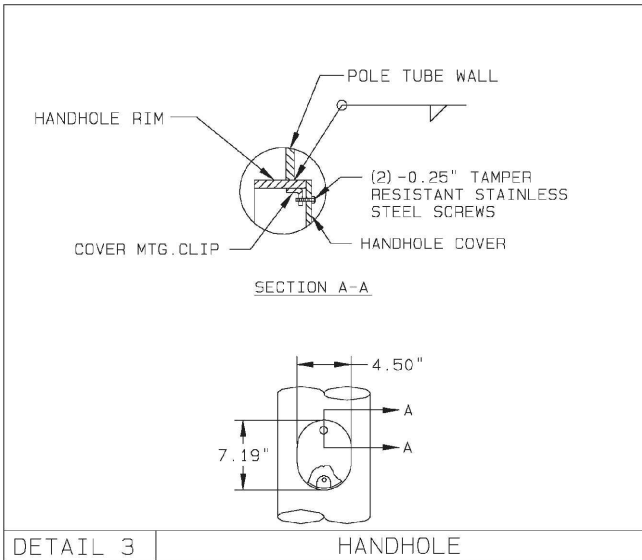

DETAIL 3 | HANDHOLE

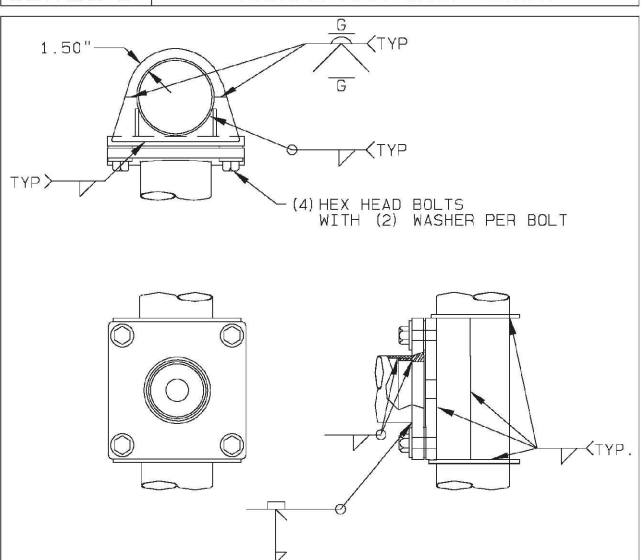

DETAIL 6 | SIGNAL ARM ATTACHMENT



CITY of WESTMINSTER
4800 WEST 92ND AVENUE
WESTMINSTER, COLO. 80031

SIGNAL POLES
DETAILS

DATE: JUNE 2019

T6

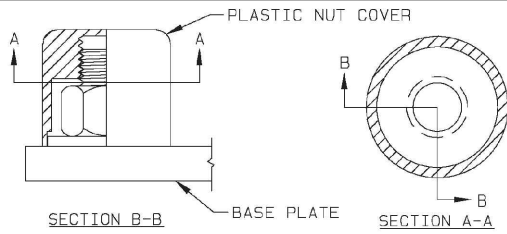

DETAIL 7 | NUT COVER

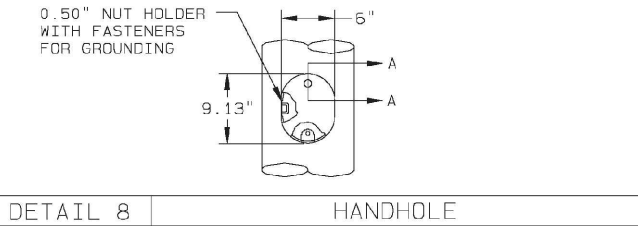
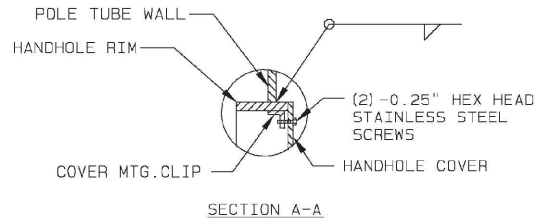

DETAIL 8 | HANDHOLE

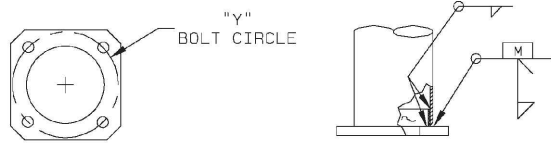

DETAIL 9 | POLE BASE

(4) -ANCHOR BOLTS WITH (2) HEX NUTS AND (2) WASHERS PER BOLT WITH THREADED END GALVANIZED AT LEAST 12.00\"/>

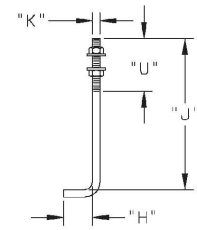

DETAIL 10 | ANCHOR BOLT

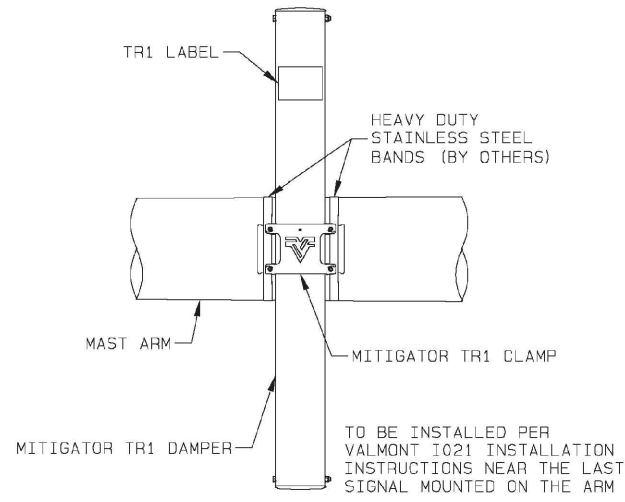

DETAIL 11 | TR1 MITIGATOR

ALL ANGLES MEASURED CLOCKWISE FROM HANDHOLE AS VIEWED FROM SMALL END OF POLE

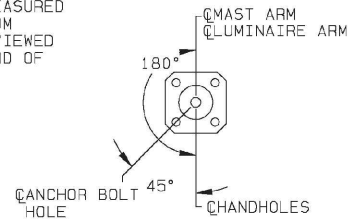

RADIAL INDEX

ALTHOUGH RARE, VIBRATIONS SEVERE ENOUGH TO CAUSE DAMAGE CAN OCCASIONALLY OCCUR IN STRUCTURES OF ALL TYPES. BECAUSE THEY ARE INFLUENCED BY MANY INTERACTING VARIABLES, VIBRATIONS ARE GENERALLY UNPREDICTABLE. THE USER'S MAINTENANCE PROGRAM SHOULD INCLUDE OBSERVATION FOR EXCESSIVE VIBRATION AND EXAMINATION FOR ANY STRUCTURAL DAMAGE OR BOLT LOOSENING. THE VALMONT WARRANTY SPECIFICALLY EXCLUDES FATIGUE FAILURE OR SIMILAR PHENOMENA RESULTING FROM INDUCED VIBRATION, HARMONIC OSCILLATION OR RESONANCE ASSOCIATED WITH MOVEMENT OF AIR CURRENTS AROUND THE PRODUCT.

VIBRATION DISCLAIMER



CITY of WESTMINSTER
 4800 WEST 92ND AVENUE
 WESTMINSTER, COLO. 80031

**SIGNAL POLES
 DETAILS**

DATE: JUNE 2019

T7

SEE VALMONT DRAWING FOR
TRAFFIC SIGNAL LAYOUT & DETAILS

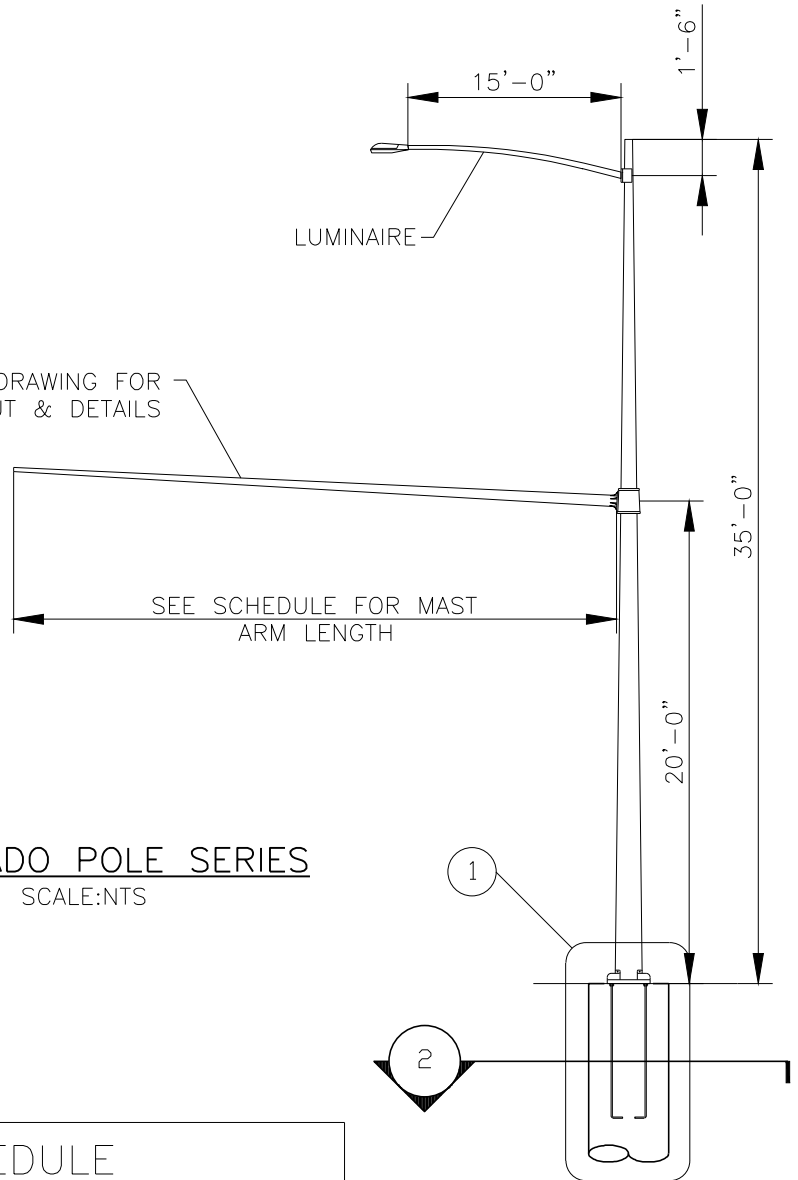

COLORADO POLE SERIES
SCALE:NTS

FOUNDATION SCHEDULE

MAST ARM LENGTH (FT.)	CAISSON DATA				
	DIA. (IN.)	DEPTH (D) (FT.)	PAY LENGTH (L) (FT.)	V BARS	
				SIZE	TOTAL
20-30	36	13.0	13.5	#9	10
35-45	42	15.0	15.5	#9	14
50-60	48	18.0	18.5	#9	18
65-70	48	20.5	21.0	#9	18



CITY of WESTMINSTER
4800 WEST 92ND AVENUE
WESTMINSTER, COLO. 80031

SIGNAL POLE CAISSON
DETAILS

DATE: JUNE 2019

T8

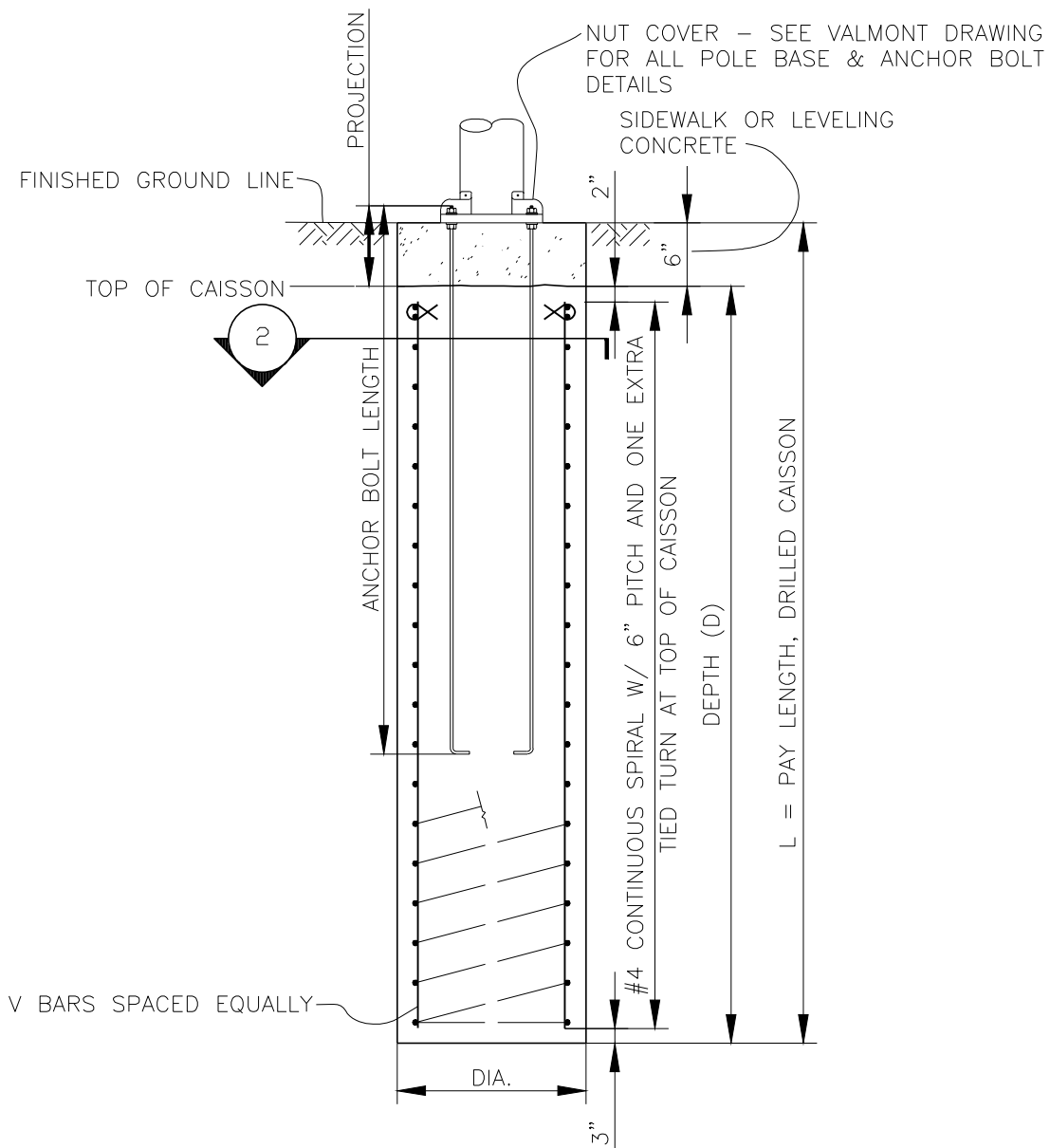

DETAIL 1

SCALE: N.T.S.

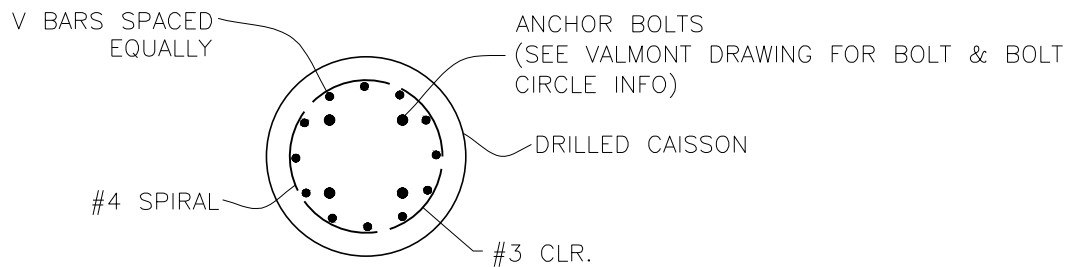

DETAIL 2

SCALE: N.T.S.



CITY of WESTMINSTER
 4800 WEST 92ND AVENUE
 WESTMINSTER, COLO. 80031

SIGNAL POLE CAISSON
 DETAILS

DATE: JUNE 2019

T9

GENERAL NOTES

1. DESIGN OF FOUNDATIONS IS BASED ON TRAFFIC SIGNAL POLE CONFIGURATIONS PROVIDED BY VALMONT INDUSTRIES, INC. DRAWING NO. TK01274 DATED 11/06/18 FOR THE CITY OF WESTMINSTER. REFER TO CITY OF WESTMINSTER TRAFFIC STANDARD DRAWINGS FOR ANY ADDITIONAL TRAFFIC POLE INFORMATION.
2. DESIGN CRITERIA: AASHTO – STANDARD SPECIFICATIONS FOR STRUCTURAL SUPPORTS FOR HIGHWAY SIGNS, LUMINAIRES AND TRAFFIC SIGNALS, 2015 EDITION.
3. A DESIGN WIND VELOCITY OF 130 MPH HAS BEEN USED FOR THE DESIGNS HEREIN (BASED ON INFORMATION FROM VALMONT). CAISSONS ARE DESIGNED FOR BASE REACTIONS PROVIDED BY VALMONT.
4. ALL FOUNDATIONS ON THIS SHEET ARE FOR SINGLE MAST ARM POLES.
5. THE DESIGNS HEREIN ASSUME THAT SIGNALS ARE INSTALLED WITHIN THE ROADWAY PRISM WITH THE FOLLOWING SOIL PARAMETERS:
 - 5.1. SOIL DENSITY = 110 LB./CU.FT.
 - 5.2. SOIL COHESION = 750 LB./SQ/FT/ FOR MEDIUM STIFF COHESIVE SOIL
 - 5.3. SOIL ϕ ANGLE = 30° FOR MEDIUM DENSE COHESIONLESS SOIL
 - 5.4. SF = 1.5 FOR TORSIONAL RESISTANCE; 3.0 FOR FLEXURAL RESISTANCE
6. CONTACT THE ENGINEER IF ANY OF THE FOLLOWING SOIL CONDITIONS ARE ENCOUNTERED DURING DRILLING:
 - 6.1. SIGNALS WILL NOT BE INSTALLED WITHIN THE ROADWAY PRISM
 - 6.2. THE SOIL HAS A HIGH ORGANIC CONTENT OR CONSISTS OF SATURATED SILT AND CLAY
 - 6.3. THE SITE WON'T SUPPORT THE WEIGHT OF THE DRILLING RIG
 - 6.4. THE FOUNDATION SOILS ARE NOT HOMOGENOUS
 - 6.5. FIRM BEDROCK IS ENCOUNTERED
 - 6.6. CAVING SOILS
 - 6.7. GROUNDWATER
 - 6.8. EXPANSIVE SOILS
 - 6.9. TRASH
 - 6.10. BOTTOM OF CAISSON WILL EXTEND BELOW BOTTOM OF ANY ADJACENT BUILDING OR RETAINING WALL FOUNDATION
 - 6.11. SLOPES GREATER THAN 10%
7. CAISSONS SHALL BE PLACED AGAINST UNDISTURBED EARTH.
8. CAISSONS SHALL BE CONSTRUCTED WITH AIR ENTRAINED CDOT CLASS BZ CONCRETE. REINFORCING STEEL SHALL BE GRADE 60.
9. FOUNDATION TO BE PROVIDED WITH 2 CONDUIT STUB OUTS. DIRECTION TO BE DETERMINED BY CITY OF WESTMINSTER ENGINEER AND IS TO BE CONSIDERED PART OF THE POLE INSTALLATION BID ITEM.
10. ANCHOR BOLTS, BASE PLATE, NUTS, AND NUT COVERS TO BE FURNISHED BY POLE MANUFACTURER.
11. CAISSON CONCRETE SHALL CURE AT LEAST SEVEN DAYS PRIOR TO THE SIGNAL STRUCTURE INSTALLATION.
12. PLUMBING OF POLES SHALL BE ACCOMPLISHED BY ADJUSTING NUTS AFTER LOADING OF MAST ARM.
13. EACH END OF CAISSON TIES TO BE TERMINATED WITH A 135° HOOK AROUND A LONGITUDINAL BAR.
14. DESIGN IS BASED ON HORIZONTAL GROUND SURFACE CONDITION IN THE VICINITY OF THE CAISSON. CAISSONS SHOULD NOT BE INSTALLED AT SITES WITH A SLOPE EXCEEDING 10 PERCENT.
15. LEVELING CONCRETE SHALL BE 3,000 PSI CLASS B AIR ENTRAINED CONCRETE.
16. YIELD STRESS OF REINFORCING STEEL SHALL BE MINIMUM 60,000 PSI.



CITY of WESTMINSTER
4800 WEST 92ND AVENUE
WESTMINSTER, COLO. 80031

SIGNAL POLE CAISSON DETAILS

DATE: JUNE 2019

T10

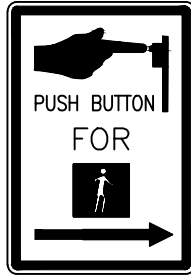

R10-3
9"x12"

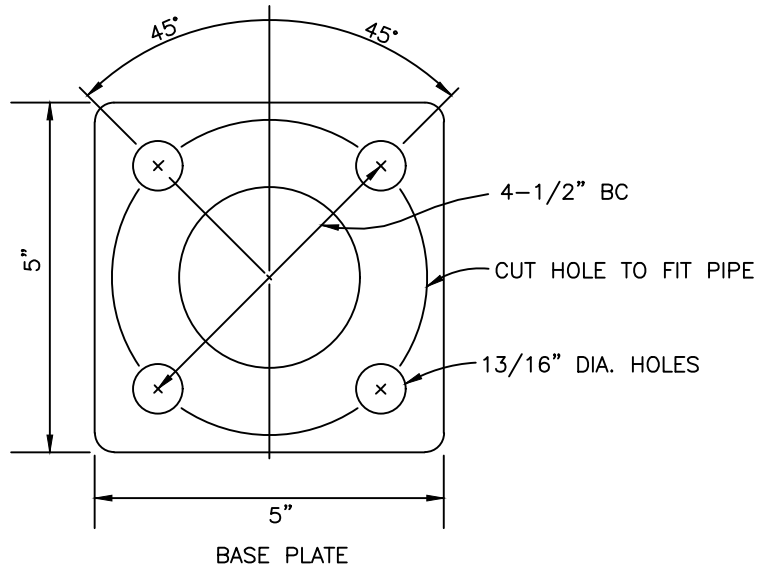
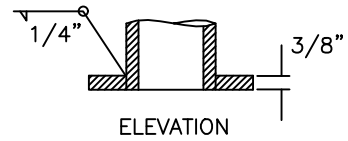
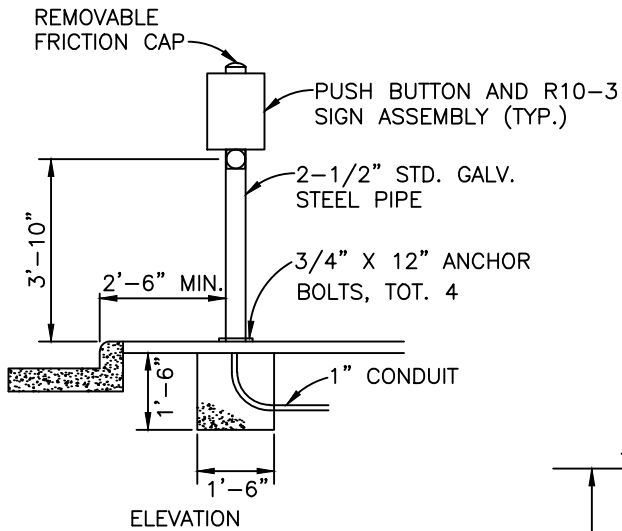

NOTE:
CONDUIT SHALL PROTRUDE 2" MAX ABOVE
FINISHED SURFACE FOUNDATION.



CITY of WESTMINSTER
4800 WEST 92ND AVENUE
WESTMINSTER, COLO. 80031

PEDESTRIAN PUSH BUTTON
POST AND SIGN

DATE: JUNE 2019

T11

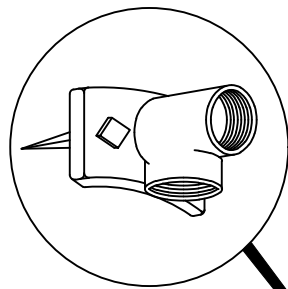

B-1
FOR WOOD POLES

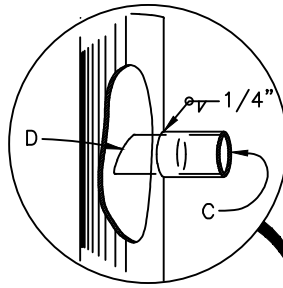

B-2
FOR STEEL POLES

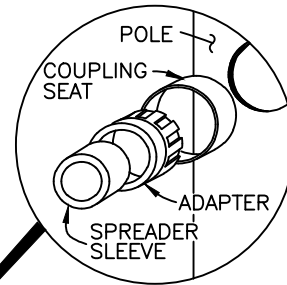

B-2
FOR ALUMINUM POLES

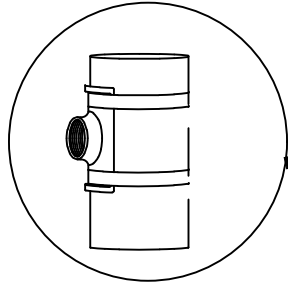

B-4

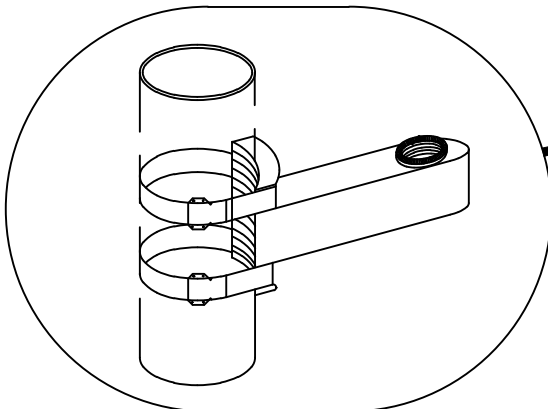
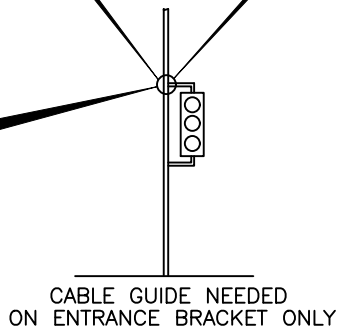

B-4 (ALTERNATIVE)

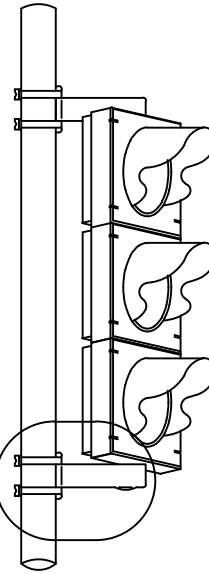

KEY

- C - 2 INCH PIPE COUPLING
- D - CABLE GUIDE. 2 INCH PIPE SHOWN. REMOVE ALL BURRS AND SHARP EDGES.

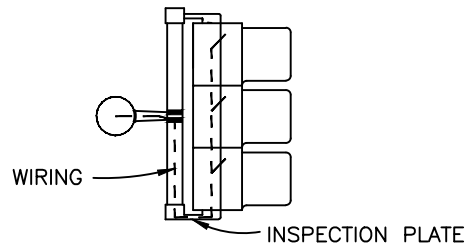

WIRING DIAGRAM



CITY of WESTMINSTER
4800 WEST 92ND AVENUE
WESTMINSTER, COLO. 80031

SIGNAL POLE AND MAST ARM
MOUNTING DETAILS

DATE: JUNE 2019

T12

GENERAL NOTES:

1. PIPE COUPLINGS FOR SIGNAL BRACKETS SHALL BE EITHER 1-1/2 OR 2 INCH DEPENDING UPON THE SIGNAL HEAD TO BE INSTALLED. SIGNAL BRACKETS SHALL BE FURNISHED BY THE MANUFACTURER OF THE SIGNAL HEADS.
2. UNLESS OTHERWISE SPECIFIED, ALL TRAFFIC SIGNALS MOUNTED ABOVE THE ROADWAY SHALL HAVE A HEIGHT OF 17'-6", ALL SIDE MOUNTED TRAFFIC SIGNALS SHALL HAVE A HEIGHT OF 10', AND PEDESTRIAN SIGNALS AT A HEIGHT OF 8' AS MEASURED TO THE BOTTOM OF THE SIGNAL HEAD HOUSING OR BRACKET.
3. ALL SIGNAL HEADS SHALL BE MOUNTED IN SUCH A MANNER AS TO BE EASILY REMOVED FROM THEIR SUPPORTING STRUCTURE.
4. GASKET SEALING COMPOUND SHALL BE USED IN ADDITION TO ANY LEAD WASHERS REQUIRED FOR CREATING A WATER-TIGHT CONNECTION BETWEEN THE SIGNAL HEAD AND MOUNTING BRACKET.
5. SIGNAL HEADS SHALL BE SECURELY AFFIXED BY THE USE OF A SERRATED COUPLING OR OTHER ACCESSORIES RECOMMENDED BY THE SIGNAL MANUFACTURER.
6. WIRING FROM INSIDE MAST ARM THROUGH 1" FIELD DRILLED HOLE IN ARM, SHALL BE BROUGHT THROUGH THE MOUNTING SUPPORT TUBE AND LOWER ARM (AS SHOWN). FIELD DRILLED HOLES SHALL HAVE RUBBER GROMMETS INSTALLED.

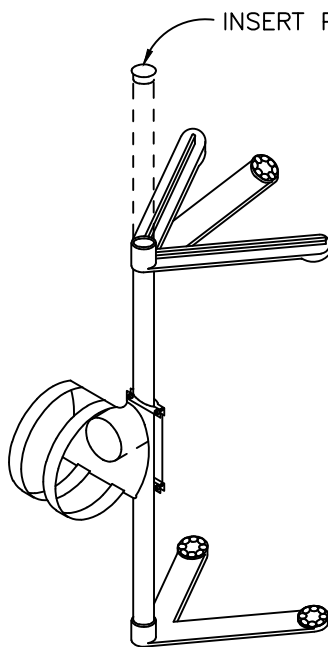

MA 5-1
MOUNTING
HARDWARE

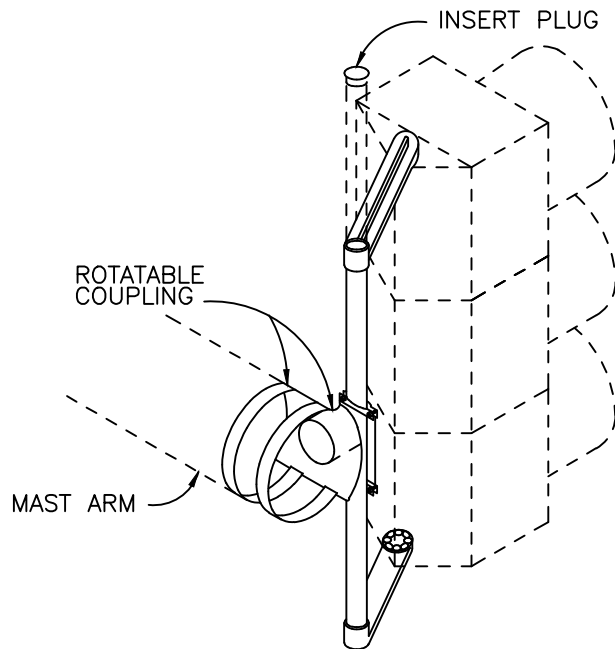

MA 5 ADJUSTABLE
MAST ARM MOUNTING
HORIZONTAL OR VERTICAL
INSTALLATION



CITY of WESTMINSTER
4800 WEST 92ND AVENUE
WESTMINSTER, COLO. 80031

SIGNAL POLE AND MAST ARM
MOUNTING DETAILS

DATE: JUNE 2019

T13

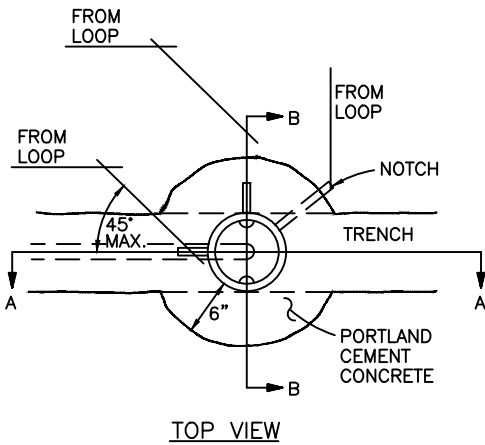

TOP VIEW

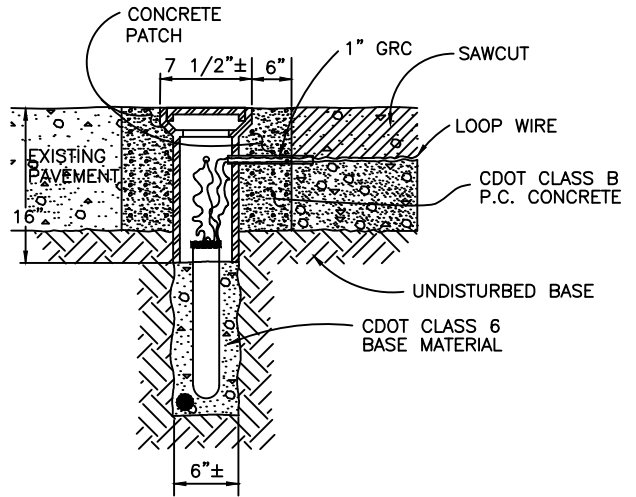

SECTION B-B

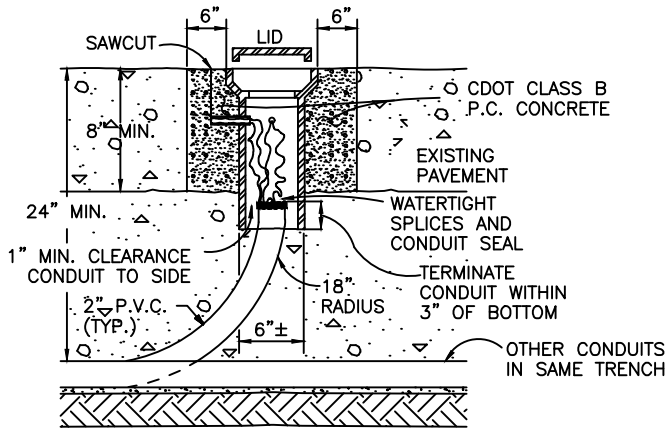

SECTION A-A

NOTES ON PULL BOX INSTALLATION:

1. PULL BOX WILL HAVE AT LEAST TWO 1" DIA. HOLES DRILLED OR TORCHED 3" FROM TOP TO ACCEPT 6" OF 1" GALVANIZED RIGID CONDUIT.
2. 4" MIN. SLACK IS TO BE PROVIDED SO THAT ALL TESTING AND SPLICING CAN BE DONE OUTSIDE OF THE PULL BOX.
3. PULL BOX LID IS TO BE SEALED WATER TIGHT BY CAULKING.
4. PULL BOX IS TO BE LOCATED IN AN AREA OF THE STREET NOT HEAVILY TRAVELED, IF POSSIBLE, AND CENTERED A MINIMUM OF 12" FROM THE CONCRETE GUTTER PAN.
5. COST OF THE PORTLAND CEMENT CONCRETE SHALL BE INCLUDED IN THE INSTALLATION OF THE PULL BOXES.
6. THE PULL BOX LID SHALL HAVE THE WORD "TRAFFIC" CAST INTO THEM.



CITY of WESTMINSTER
 4800 WEST 92ND AVENUE
 WESTMINSTER, COLO. 80031

LOOP DETECTOR/PULL BOX
 DETAILS
 WATER VALVE STEM TYPE (wvPB)

DATE: JUNE 2019

T14

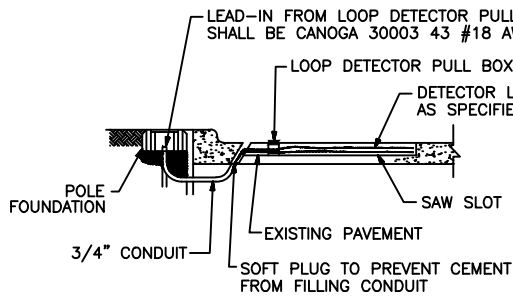

SECTION A-A

NOTE: FINISHED LOOP MUST SHOW NO SHORTED TURNS NO BROKEN WIRE AND 15 MEGOHMS (MINIMUM) TO GROUND, MEASURED WITH A QUALITY MEGOHM METER (SEE GENERAL NOTES).

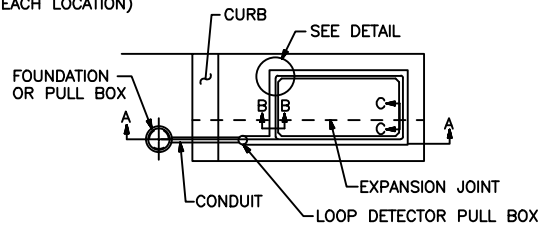

STANDARD LOOP

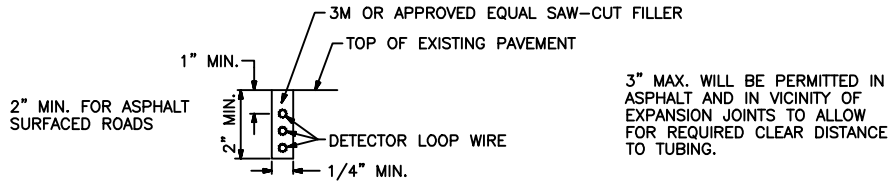

SECTION B-B

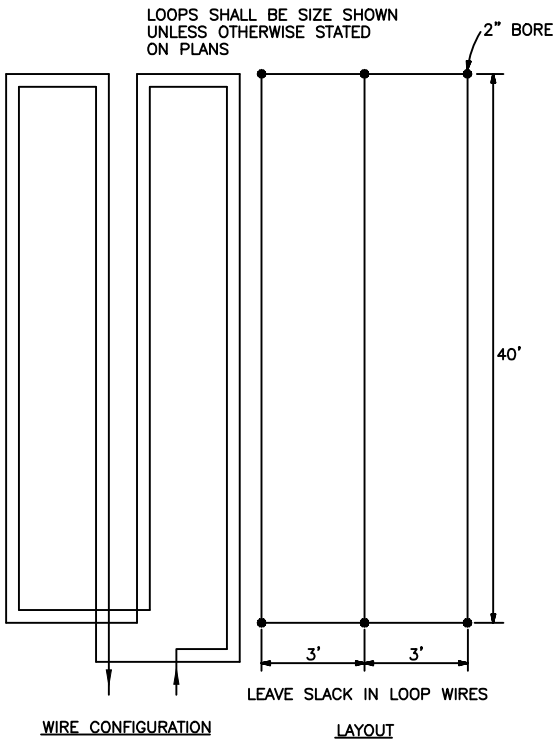

LOOP DETECTOR INSTALLATION DETAIL
NO SCALE

GENERAL NOTES FOR TD-5 DETECTORS:

1. LOOP SIZE AND LOCATION SHALL BE AS SHOWN IN THE PLANS.
2. THE NUMBER OF TURNS OF WIRE SHALL BE AS INDICATED IN THE PLANS OF THE SPECIFIC INSTALLATION OR AS OTHERWISE SPECIFIED BY THE EQUIPMENT MANUFACTURER SUPPLYING THE LOOP DETECTOR AMPLIFIERS AND APPROVED BY THE TRAFFIC ENGINEERING DIVISION. ALL LOOP WIRE IN ADJACENT LOOPS SHALL BE LAID EITHER IN A CLOCKWISE OR COUNTER-CLOCKWISE DIRECTION AND THE LEADS TAGGED AT THE TIME OF INSTALLATION TO CLEARLY IDENTIFY THEIR DIRECTION.
3. IMMEDIATELY BEFORE LAYING THE LOOP CABLE, THE SAW CUT SHALL BE THOROUGHLY CLEANED AND DRIED WITH HIGH PRESSURE COMPRESSED AIR.
4. THE WIRE SHALL BE POSITIONED BY USE OF A BLUNT INSTRUMENT SO AS TO MINIMIZE THE CHANCE OF DAMAGE TO THE CABLE INSULATION. (THE USE OF A SCREWDRIVER, SAW BLADE, ETC. WILL NOT BE PERMITTED.)
5. LOOP WIRE SHALL BE CONTINUOUS (NO SPLICES PERMITTED) FROM THE PULL BOX OR FOUNDATION THROUGHOUT THE LOOP CONFIGURATION.
6. AFTER THE LOOP WIRE IS INSTALLED, 3M OR APPROVED EQUAL SAW-CUT SEALER SHALL BE USED TO FILL THE SAW CUT BEFORE MOISTURE OR DIRT CAN ACCUMULATE. LOOP INSTALLATION MAY BE RESTRICTED DUE TO ADVERSE CLIMATICAL CONDITIONS (DAMPNESS, DUST, ETC.)
7. SPLICES TO THE LOOP LEAD-IN CABLE SHALL BE WATERPROOFED WITH 3M SPLICE KITS OR APPROVED EQUAL.
8. ELECTRICAL CONTINUITY TESTS SHALL BE PERFORMED FOR EACH LOOP:
 - A. BEFORE ANY LOOP SEALER IS INSTALLED.
 - B. AFTER LOOP SEALER IS PLACED BUT PRIOR TO CONNECTION TO LEAD-IN CABLE.
 - C. AFTER LEAD-IN CABLE IS SPLICED AND TRAINED TO THE CONTROLLER.

IN ADDITION, "RESISTANT-TO-GROUND" AND "INDUCTANCE" OF EACH LOOP SHALL BE MEASURED AND RECORDED FOR EACH OF THE THREE TESTS PERFORMED TO THE LOOP DETECTOR.



CITY of WESTMINSTER
4800 WEST 92ND AVENUE
WESTMINSTER, COLO. 80031

LOOP DETECTOR DETAILS

DATE: JUNE 2019

T15

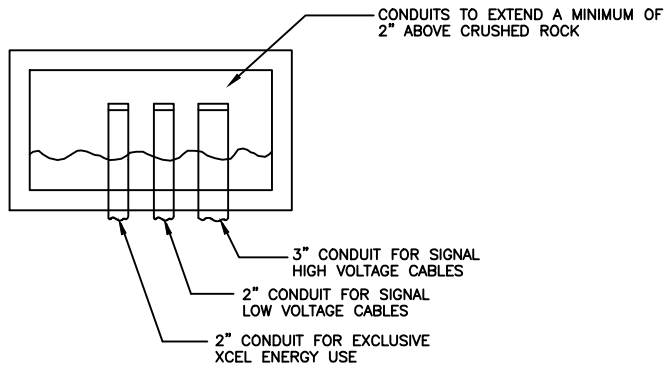

TYPICAL PULL BOX

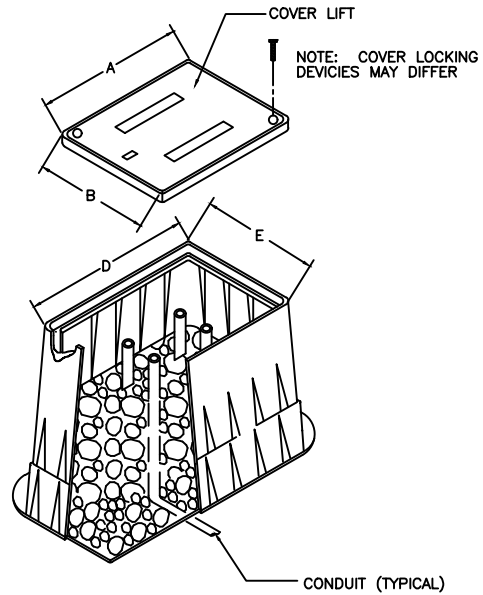

PLASTIC PULL BOX DETAIL FOR USE IN GRASS/GROUND AREAS

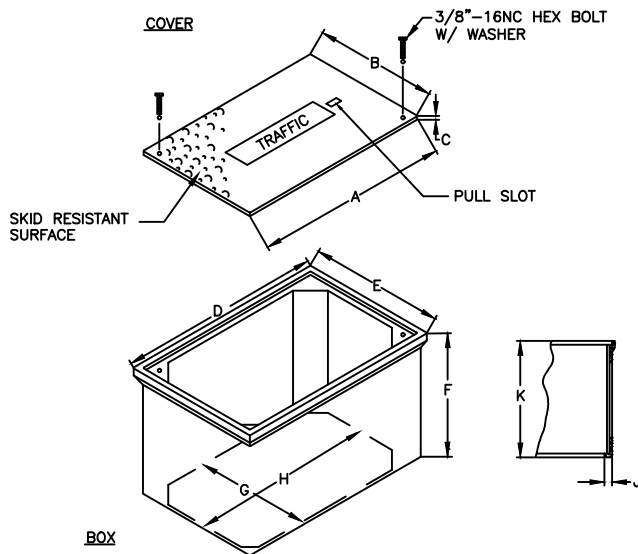

FIBERGLASS REINFORCED POLYMER CONCRETE DESIGNED FOR FULL VEHICULAR TRAFFIC (20,000 LB. LOADING)

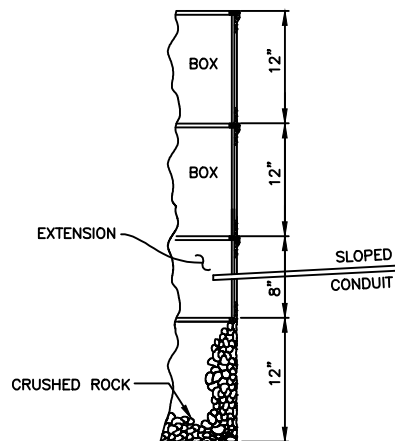

TWO BOXES AND EXTENSION

TABLE OF DIMENSIONS (MINIMUMS)

DESCRIPTION	DIMENSIONS (IN.)										TO BE USED AT
	A	B	C	D	E	F	G	H	J	K	
LARGE 18x30 2 BOXES & EXT.	31 1/4	18 1/4	3/4	33 1/8	20 1/8	12	16 3/8	29 3/8	1/2	11 1/4	CONTROLLER CABINET
MEDIUM 12x18 2 BOXES & EXT.	11 1/2	18 1/2	5/8	20 1/2	13 1/2	12	10 1/4	17 1/4	3/8	11 1/4	TRAFFIC SIGNAL POLE
SMALL 12x12 SINGLE BOX	12 7/8	12 7/8	5/8	14	14	12 3/4	10 1/2	10 1/2	1	12	UPSTREAM DETECTOR SPLICES, INTERCONNECT

PRECAST PULL BOX FOR USE IN CONCRETE/ASPHALT/
SIDEWALK AREAS BEHIND CURB

SEE CONTRACT DOCUMENTS FOR MATERIAL SPECIFICATIONS.



CITY of WESTMINSTER
4800 WEST 92ND AVENUE
WESTMINSTER, COLO. 80031

TRAFFIC SIGNAL
PULL BOX

DATE: JUNE 2019

T16

TRAFFIC SIGNAL PLAN: GENERAL INSTALLATION NOTES

1. ALL CABINET DIMENSIONS ARE NOMINAL.
2. CABINET SHALL BE BONDED TO THE GROUND ROD.
3. CABINET BASES SHALL BE FIBERGLASS.
4. IF TELEPHONE INTERCONNECT IS SPECIFIED, A MINIMUM OF 5 INCHES CLEAR VERTICAL SPACE SHALL BE LEFT BENEATH ALL OTHER EQUIPMENT INSIDE THE CABINET.
5. ALL STRANDED WIRES TERMINATED IN THE CABINET UNDER A BINDER HEAD SCREW SHALL BE EQUIPPED WITH A SOLDERLESS, PRESSURE TYPE SPADE CONNECTOR WITH A PRE-INSULATED SHANK. ONLY ONE WIRE SHALL BE USED WITH EACH SPADE CONNECTOR. NO MORE THAN THREE CONDUCTORS SHALL BE CONNECTED TO ANY ONE TERMINAL ON THE TERMINAL BOARD PROVIDED IN THE CABINET.
6. CONTROLLERS AND RELAYS SHALL BE LOCATED TO PERMIT SAFE AND EASY REMOVAL.
7. IF THE CABINET IS LOCATED IN AN UNPAVED AREA, A RAISED CONCRETE PAD SHALL BE PROVIDED.
8. ALL CONCRETE SHALL BE PER CITY OF WESTMINSTER STANDARD SPECIFICATIONS FOR DESIGN AND CONSTRUCTION.
9. THE ENDS OF THE SPARE CONDUCTORS SHALL NOT BE CUT BACK. SPARE CONDUCTORS SHALL BE NEATLY COILED AND TAPED FOR POSSIBLE FUTURE USE. ALL CABLES SHALL BE CLEARLY IDENTIFIED IN THE CABINET BY MEANS OF METAL OR DURABLE PLASTIC TAGS.
10. WORK SHALL BE NEAT, UNCLUTTERED "FIRST-CLASS" WORKMANSHIP AND SHALL CONFORM TO APPLICABLE SECTIONS OF THE NATIONAL ELECTRIC CODE, CURRENT EDITION, AND ANY LOCAL REGULATIONS.
11. ALUMINISTIC OR CAULKING COMPOUND SHALL BE USED WHEREVER THE CABINET COMES IN CONTACT WITH THE BASE TO INSURE WEATHER TIGHTNESS. ALUMINISTIC COMPOUND WILL BE REQUIRED IF THE CABINET IS CONSTRUCTED FROM ALUMINUM.
12. THE ITEMS TRAFFIC SIGNAL-LIGHT POLE AND TRAFFIC SIGNAL-LIGHT SPAN WIRE POLE SHALL INCLUDE THE EXTENSION OF THE POLE AND THE MAST ARM FOR THE MOUNTING OF THE LUMINAIRE.
13. ALL REINFORCING STEEL SHALL BE CITY OF WESTMINSTER STANDARD SPECIFICATIONS FOR DESIGN AND CONSTRUCTION.



CITY of WESTMINSTER
4800 WEST 92ND AVENUE
WESTMINSTER, COLO. 80031

TRAFFIC SIGNAL
GENERAL INSTALLATION NOTES

DATE: JUNE 2019

T17

CABINET REQUIREMENTS

1. THE CABINET SHALL BE CONSTRUCTED OF 0.125 MINIMUM THICKNESS BARE ALUMINUM. CABINETS SHALL BE BRACED INTERNALLY OR BY FOLDED SEAMS IN ORDER TO PROVIDE SUFFICIENT RIGIDITY TO WITHSTAND NORMAL HANDLING AND TRANSPORT TO THE FIELD LOCATION WITHOUT DEFORMING.
2. THE MAIN DOOR SHALL HAVE A SELF LOCKING, KEYED, TUMBLER LOCK WITH TWO KEYS. HINGES SHALL BE MOUNTED ON THE CABINET IN SUCH A WAY THAT INTERCHANGEABILITY OF DOORS IS POSSIBLE BETWEEN CABINETS OF LIKE SIZE AND MANUFACTURER. HINGE PINS SHALL BE STAINLESS STEEL. DOORS SHALL HAVE NEOPRENE GASKETS OF SUFFICIENT THICKNESS TO PROVIDE A RAIN-TIGHT AND DUST-TIGHT SEAL.
3. IN ADDITION TO THE MAIN DOOR, AN AUXILIARY DOOR SHALL BE PROVIDED EQUIPPED WITH A LOCK AND POLICE KEY. THIS AUXILIARY DOOR SHALL PROVIDE ACCESS TO THE PANEL WHICH SHALL CONTAIN:

- A. A SWITCH TO CHANGE FROM NORMAL TO FLASH OPERATION.
- B. A SIGNAL ON/OFF SWITCH WHICH WILL NOT AFFECT CONTROLLER OPERATION.
- C. ANY ADDITIONAL EQUIPMENT WHICH MAY BE REQUIRED BY THE SPECIAL PROVISIONS.

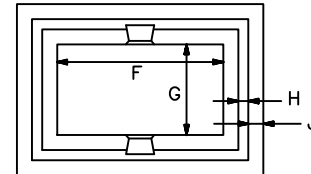

4. ALL CABINETS SHALL HAVE A SUITABLE DESIGNED VENT TO ALLOW ANY EXPLOSIVE ATMOSPHERE TO ESCAPE FROM THE CABINET INTERIOR.
5. THE CABINET SHALL BE FURNISHED COMPLETE INCLUDING TWO MOUNTING TABLES, CAPABLE OF SUPPORTING 75 POUNDS EACH.
6. A LAMP RECEPTACLE AND CONVENIENCE OUTLET, WIRED FOR 120 VOLT, 60 HZ, SHALL BE PROVIDED IN ALL CABINETS.
7. THE CABINET SHALL BE PROVIDED WITH ALL NECESSARY OPENINGS FOR MOUNTING AND CONNECTIONS OF EQUIPMENT SPECIFIED FOR THE PARTICULAR JOB.
8. ALL CONNECTIONS OF INCOMING CONDUCTORS SHALL BE NEAT AND FIRM AND MADE TO A TERMINAL BOARD PROVIDED IN THE CABINET. THE TERMINAL BOARD SHALL BE LOCATED AT LEAST THREE INCHES FROM THE BOTTOM OF THE CABINET AND ARRANGED FOR ADEQUATE ELECTRICAL CLEARANCE BETWEEN THE TERMINALS AND SIDEWALKS. THIS BOARD SHALL PROVIDE AT LEAST:

- A. A TERMINAL FOR CIRCUIT BREAKER FOR POWER SUPPLY LINE.
- B. A TERMINAL UNFUSED, FOR THE NEUTRAL SIDE OF SUPPLY LINE.
- C. TERMINALS FOR DETECTOR CABLES.
- D. TERMINALS FOR SIGNAL LIGHT CABLES, AT LEAST ONE FOR EACH SIGNAL CIRCUIT AND ASSOCIATED COMMON CONDUCTORS.

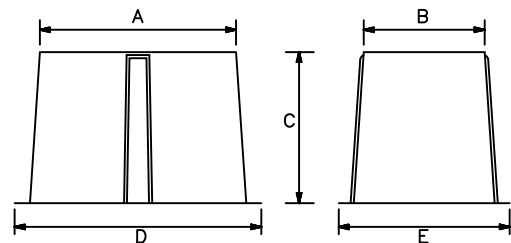

9. CONNECTIONS BETWEEN THE TERMINAL BOARD AND THE CONTROLLER (INCLUDING ALL ASSOCIATED EQUIPMENT) SHALL BE MADE BY USING MULTI-TERMINAL PLUG RECEPTACLE INCORPORATED WITH THE CONTROLLER, DETECTOR AMPLIFIERS OR OTHER APPARATUS.
10. THE SAME POLARITY SHALL BE MAINTAINED WITH THE TRAFFIC SIGNAL CIRCUITS AS THE POWER SUPPLY LEADS. PROVISION FOR GROUNDING THE CABINET TO THE GROUND SIDE OF THE POWER SUPPLY SHALL BE MADE.
11. A RADIO INTERFERENCE SUPPRESSOR CONSISTING OF CHOKE COILS AND/OR CONDENSERS SHALL BE PROVIDED WITH ALL FLASHER CONTACTS.
12. MOUNTING BRACKETS AND HARDWARE SHALL BE PLACED SO AS TO LOCATE ALL EQUIPMENT WITHIN EASY ACCESS OF THE CABINET DOOR OPENING.

TYPE	A	B	C	D	E	F	H	J
M-BASE	30	18	24	39	27	24	2	2.5
OTHER	36	24	24	46	34	31	1.5	3.5
P-BASE	44	26	24	54	36	37	2	3

FIBERGLASS CABINET BASE

NO SCALE

CABINET BASE MATERIALS

RESIN

TO BE A VIRGIN AND NOT A DISTRESSED POLYESTER THERMOSETTING RESIN. THE MATERIAL SHALL BE TESTED FOR FLAMMABILITY UNDER ASTM-D635 WITH A RATING TO BE SELF-EXTINGUISHING AND WITH AN EXTENT OF BURNING NOT TO BE OVER 12MM NOR AVERAGE TIME BURNING TO BE OVER EIGHTY SECONDS ON TEST. SHALL ALSO MEET UL-90 CLASSIFICATION AND SHALL HAVE A V-0 RATING.

FIBERGLASS

FIBERGLASS SHALL BE A COMBINATION OF CHOPPED GLASS WITH A MINIMUM OF ONE LAYER THROUGHOUT OF 18 OUNCE WOVEN ROVING SO AS TO FORM A CONTINUOUS FILAMENT FROM TOP TO BOTTOM AND FROM ONE SIDE TO THE OTHER FOR MAXIMUM STRENGTH. THE OVERALL LAMINATE SHALL BE A MINIMUM OF 1/4 INCH.

GELCOAT

THE EXTERIOR SURFACE SHALL BE COATED WITH A POLYESTER BASE GELCOAT OR A SURFACECOAT THAT WILL PROVIDE MAXIMUM PROTECTION FROM UV LIGHT AND WEATHERING. TEST DATA RESULTS FROM DSET LABORATORIES USING THE EMMAQUA TEST METHOD WITH THE RESULTS OF THE EQUIVALENT OF TWO STANDARD ULTRA-VIOLET LIGHT YEARS SHOWING NO CHANGE IN FIBER SHOW OR FIBER BLOOM AND NO WORSE THAN A "GOOD" RATING ON GENERAL APPEARANCE AND COLOR CHANGE.

AN ALTERNATE TEST FOR UV RESISTANCE CAN BE THE ASTM-G-70 TEST METHOD WITH A MAXIMUM OF CHANGE OF 2.3 MACADAM UNITS AFTER ONE THOUSAND HOURS OF EXPOSURE IN A MODEL 65WR ATLAS WEATHEROMETER.



CITY of WESTMINSTER
 4800 WEST 92ND AVENUE
 WESTMINSTER, COLO. 80031

CABINET REQUIREMENTS

DATE: JUNE 2019

T18

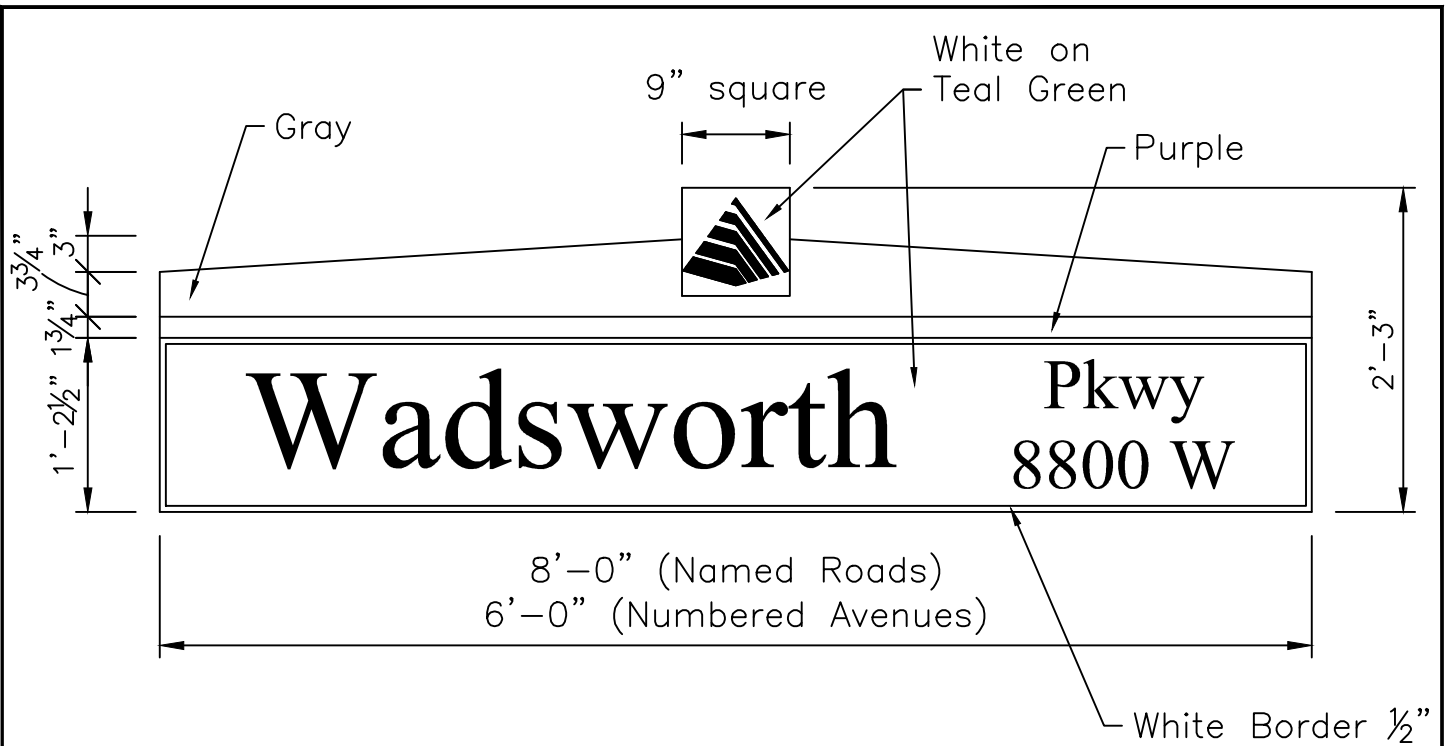

INTERNALLY ILLUMINATED – SINGLE SIDED

Street Name Signs – Traffic Signal Mast Arm Mount

Street Name = 8 inch Times Roman Bold (upper/lower case)
 Street Prefix/Suffix & Hundred Block = 5 Inch Times Roman Bold

*** ALL LETTERING SHALL BE BOLD ***
 *** CONCEPTUAL DESIGN – STREET NAME AND SUFFIX SHOWN ARE
 EXAMPLES ONLY ***



CITY of WESTMINSTER
 4800 WEST 92ND AVENUE
 WESTMINSTER, COLO. 80031

INTERNALLY ILLUMINATED
 STREET SIGN

DATE: JUNE 2019

T19

DETAIL "A"

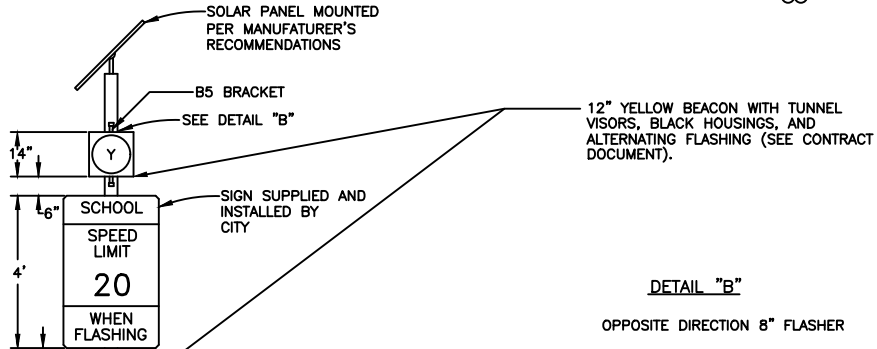
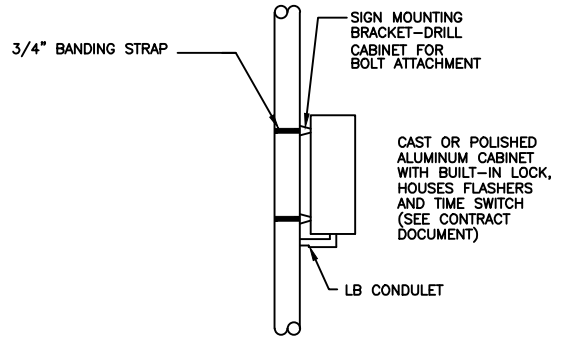

DETAIL "B"

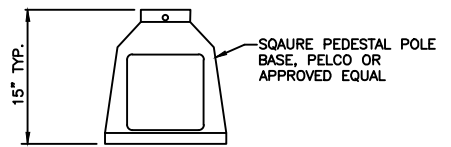
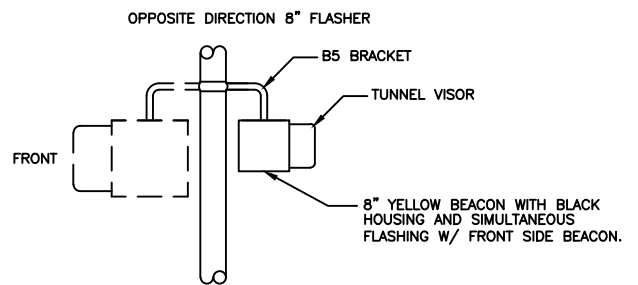

DETAIL "C"



CITY of WESTMINSTER
 4800 WEST 92ND AVENUE
 WESTMINSTER, COLO. 80031

**SCHOOL FLASHING
 BEACON ASSEMBLY
 SIDE OF ROAD**

DATE: JUNE 2019

T20

FRONT VIEW
 40"x60" SIGN TO BE
 SUPPLIED BY THE CITY
 AND INSTALLED BY CONTRACTOR

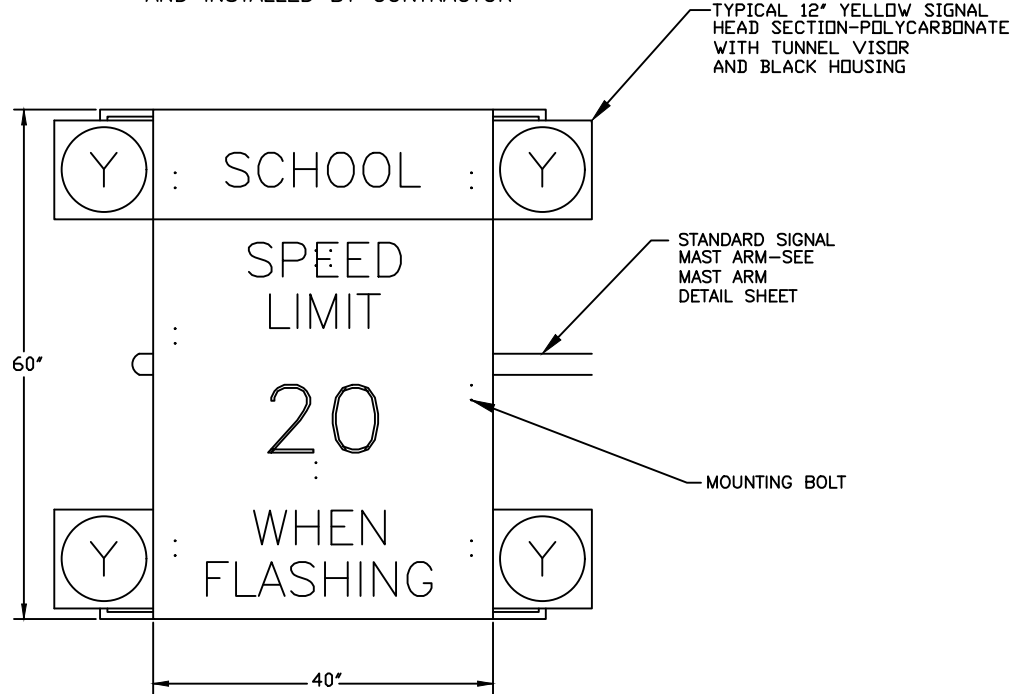

FLASHING SEQUENCE SHALL BE:

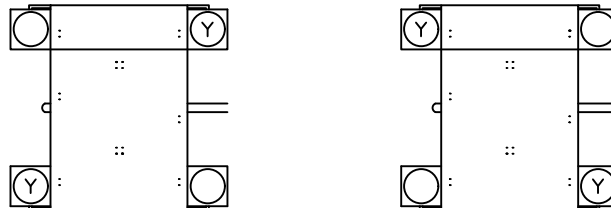

PLACEMENT NOTES:

1. ROADWAY WITH ONE THROUGH LANE: SIGN AND FLASHER ASSEMBLY CENTERED ON THROUGH LANE.
2. ROADWAY WITH TWO THROUGH LANES: SIGN AND FLASHER ASSEMBLY CENTERED ON LANE LINE BETWEEN THROUGH LANES.
3. ROADWAY WITH THREE THROUGH LANES: SIGN AND FLASHER ASSEMBLY CENTERED ON CENTER THROUGH LANE.



CITY of WESTMINSTER
 4800 WEST 92ND AVENUE
 WESTMINSTER, COLO. 80031

SCHOOL FLASHING
 BEACON ASSEMBLY
 OVERHEAD

DATE: JUNE 2019

T21

CABINET AND FLASHER
DETAIL

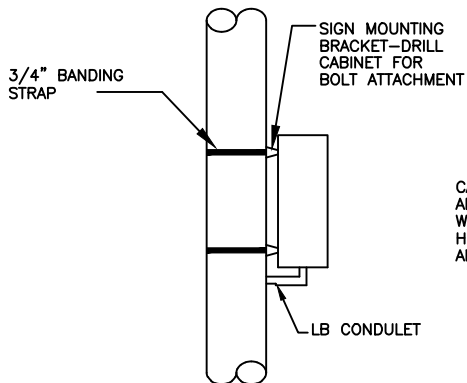

CAST OR POLISHED ALUMINUM CABINET WITH BUILT-IN LOCK, HOUSES FLASHERS AND TIME SWITCH

BACK VIEW

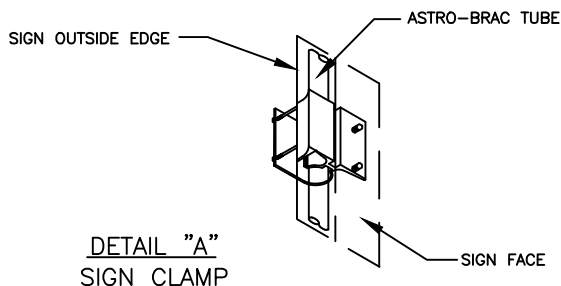
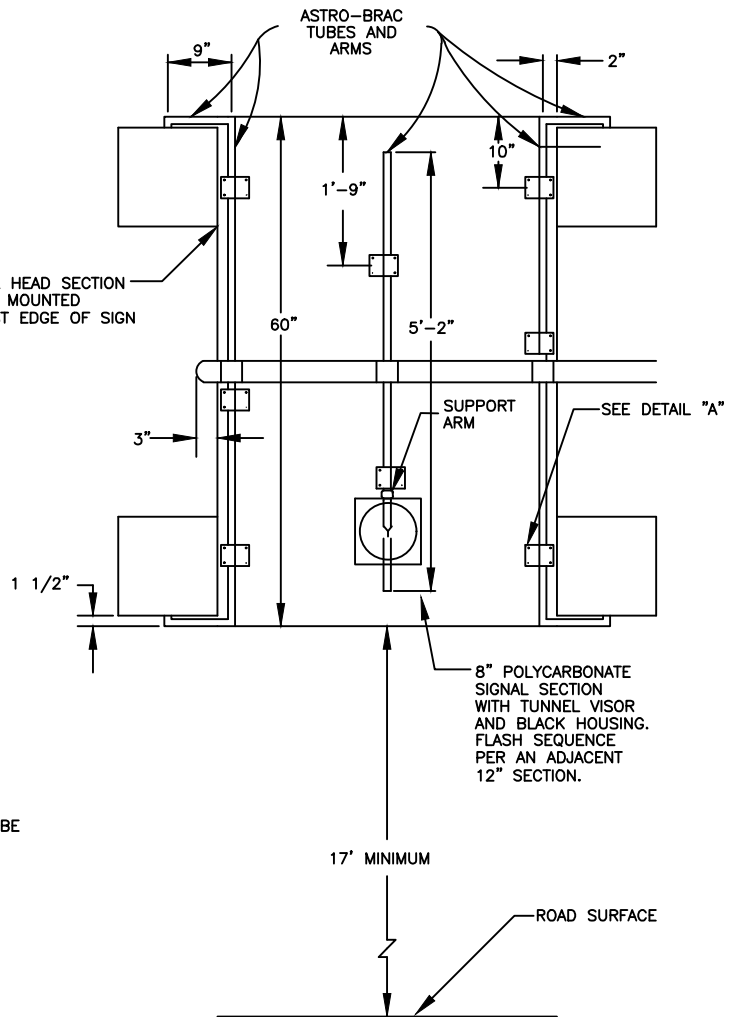

CITY of WESTMINSTER
4800 WEST 92ND AVENUE
WESTMINSTER, COLO. 80031

SCHOOL FLASHING
BEACON ASSEMBLY
OVERHEAD

DATE: JUNE 2019

T22

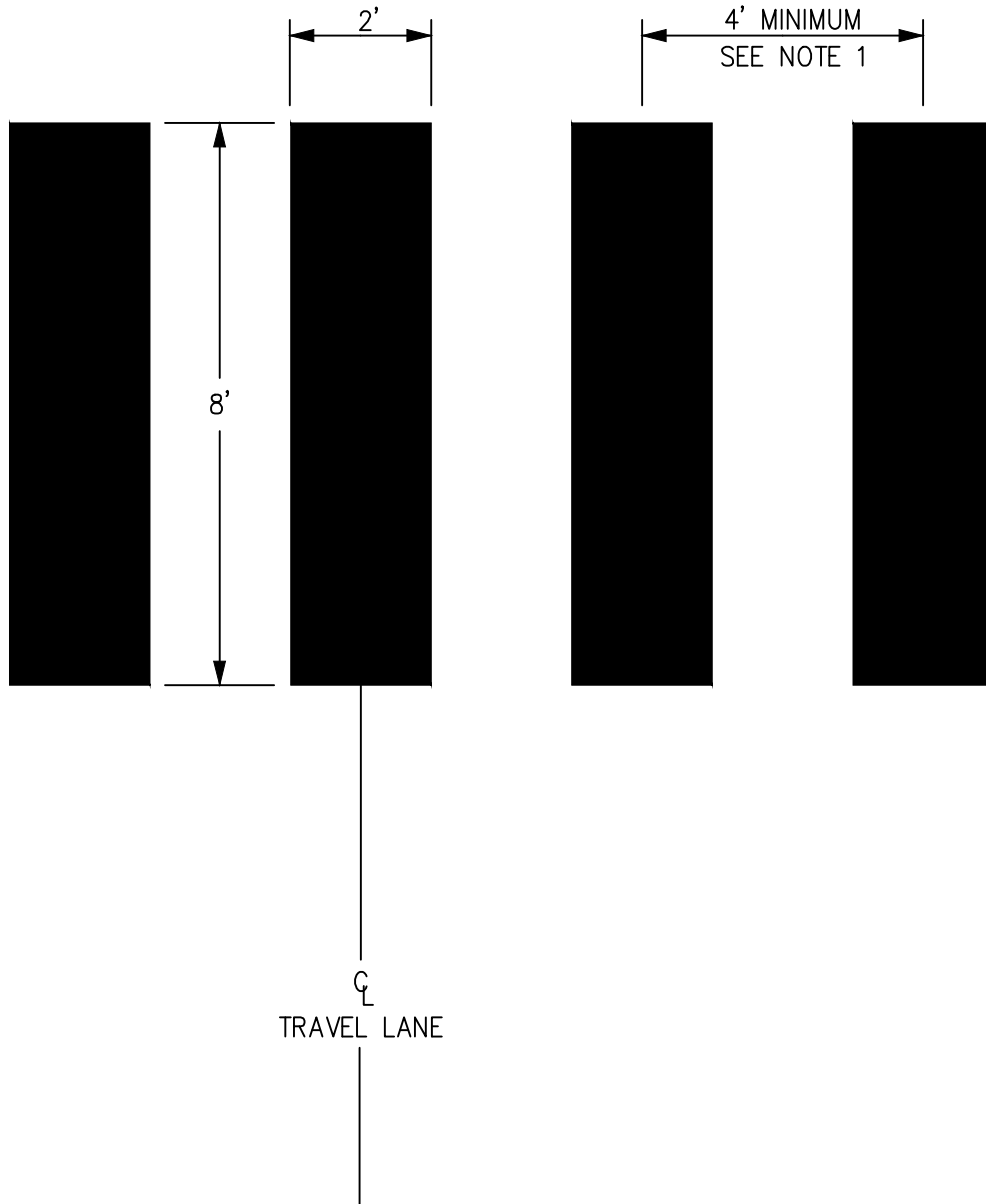

NOTES

1. FIELD ADJUST SPACING TO AVOID VEHICLE TIRE PATHS.
2. SET BARS ON LANE LINES AND BETWEEN WHEEL PATH.

NOT TO SCALE



CITY of WESTMINSTER
 4800 WEST 92ND AVENUE
 WESTMINSTER, COLO. 80031

**CROSSWALK
 STRIPING**

DATE: JUNE 2019

T23

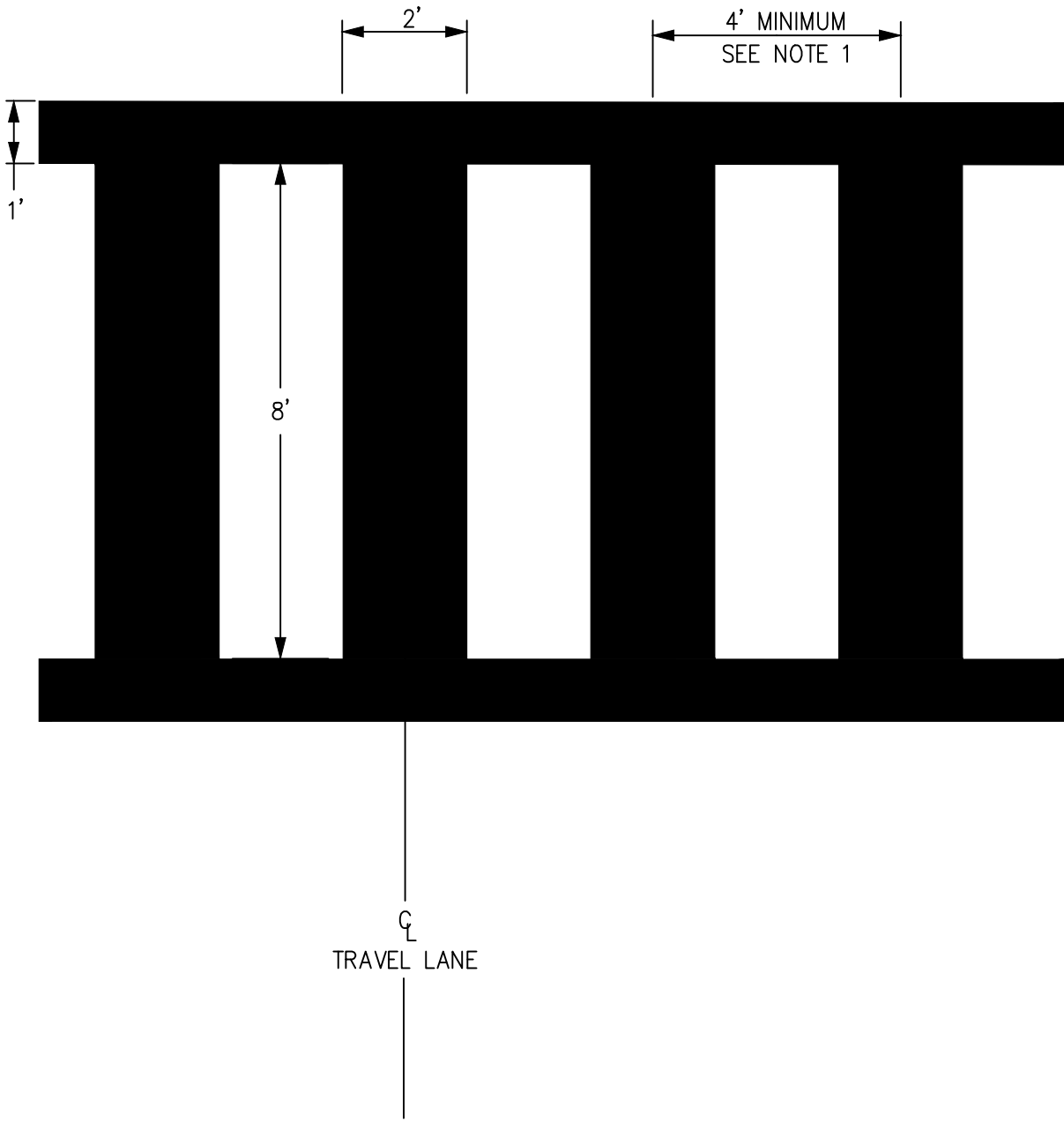

NOTES

1. FIELD ADJUST SPACING TO AVOID VEHICLE TIRE PATHS.
2. SET BARS ON LANE LINES AND BETWEEN WHEEL PATH.
3. 12 INCH BAR SHALL EXTEND FROM EDGE OF GUTTER TO EDGE OF GUTTER.

NOT TO SCALE



CITY of WESTMINSTER
 4800 WEST 92ND AVENUE
 WESTMINSTER, COLO. 80031

SCHOOL ZONE OR ROUTE
 CROSSWALK STRIPING

DATE: JUNE 2019

T24

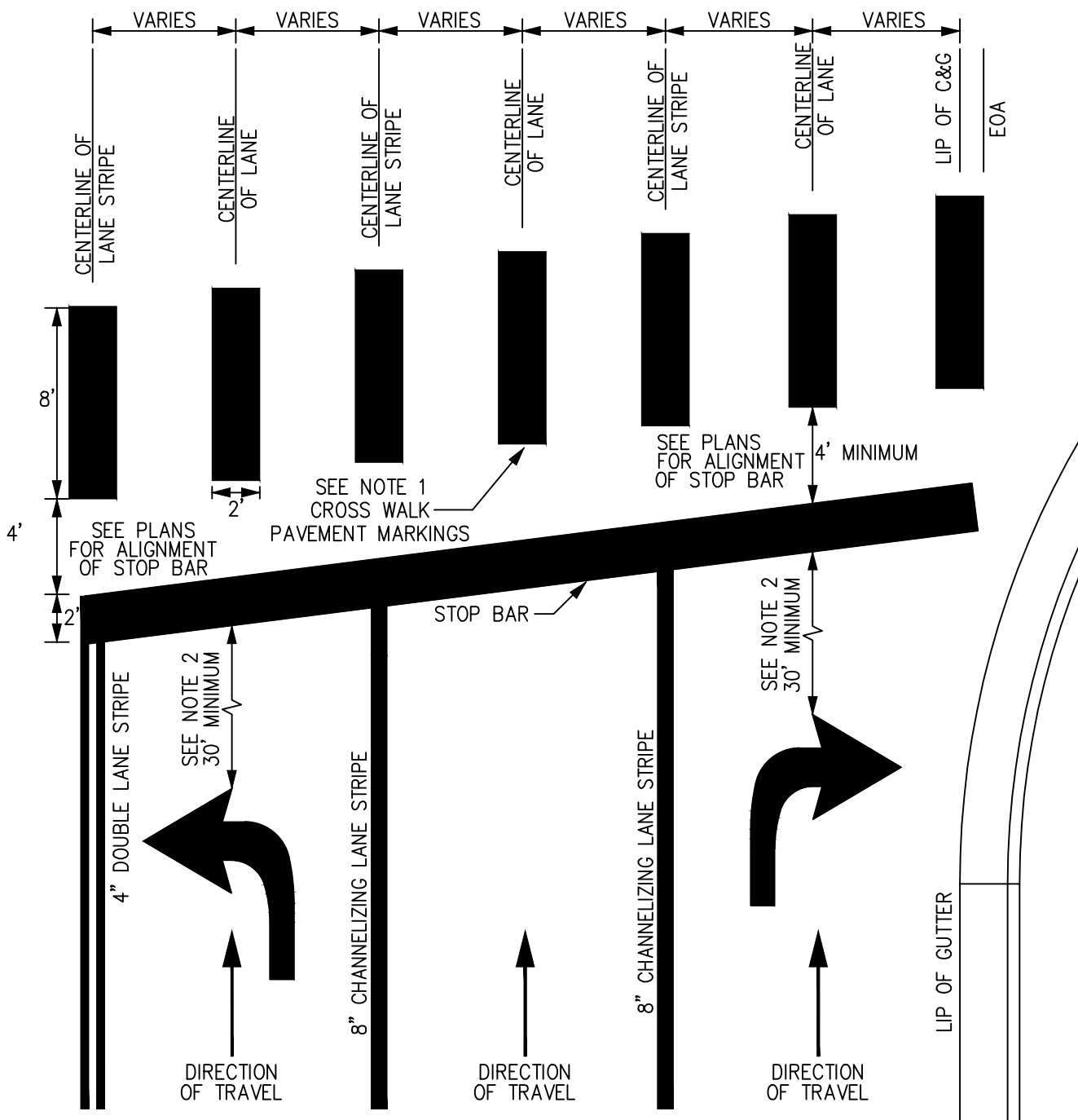

NOTES

1. CROSS WALK PAVEMENT MARKINGS ARE TO BE ALIGNED PARALLEL WITH TRAFFIC FLOW AND CENTERED ON CENTERLINE OF PEDESTRIAN RAMP, UNLESS OTHERWISE DIRECTED.
2. 30' MINIMUM DISTANCE WHEN STORAGE LENGTH EXCEEDS 200 FEET, AND TWO TURN ARROWS ARE REQUIRED.

NOT TO SCALE



CITY of WESTMINSTER
 4800 WEST 92ND AVENUE
 WESTMINSTER, COLO. 80031

**CROSSWALKS AND
 STOP BAR DETAIL**

DATE: JUNE 2019

T25

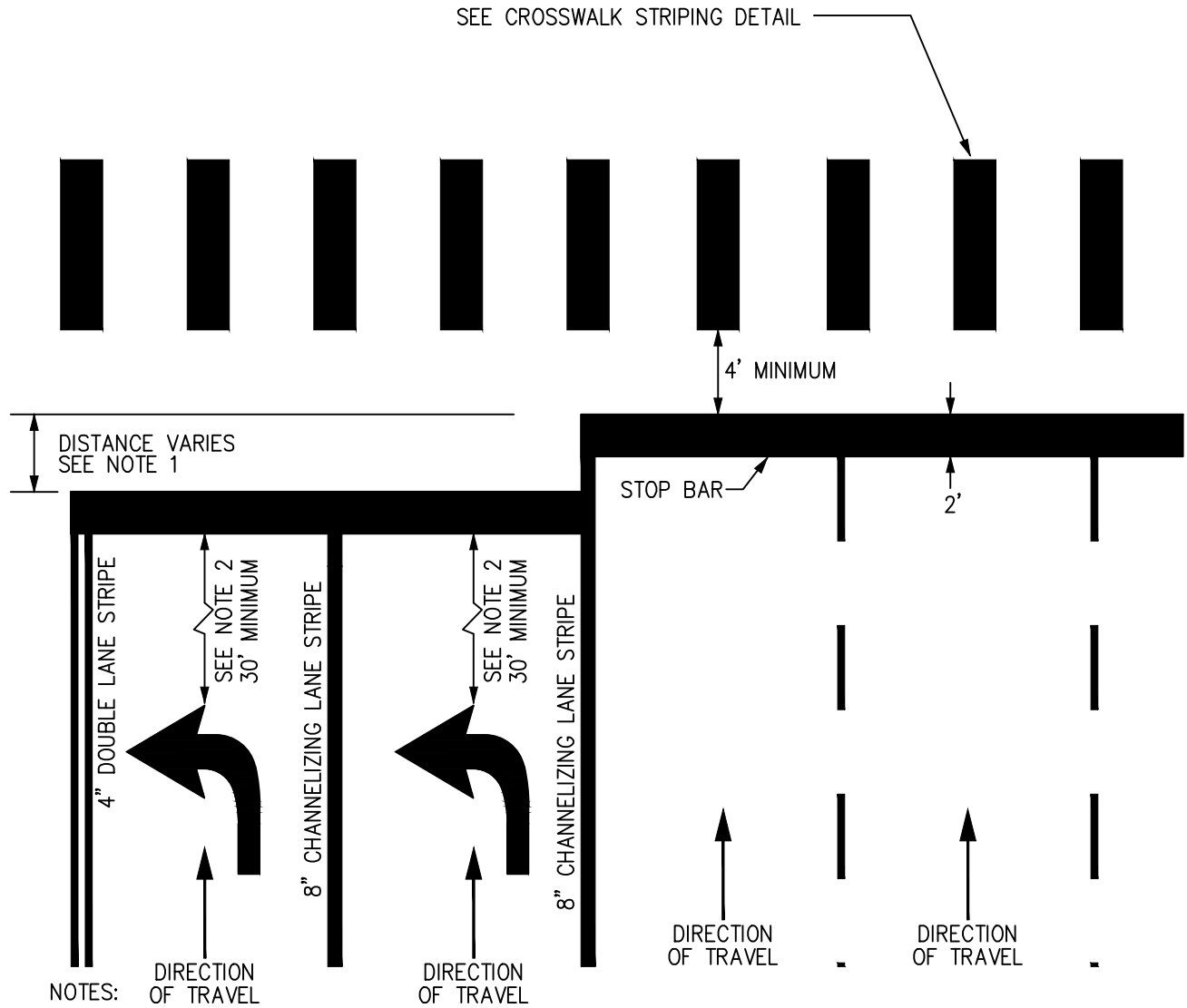

NOTES

1. DISTANCE TO BE FIELD DETERMINED TO ACCOMMODATE TURNING RADIUS; LAYOUT TO BE APPROVED BY THE TRAFFIC ENGINEER PRIOR TO INSTALLATION.
2. 30' MINIMUM DISTANCE WHEN STORAGE LENGTH EXCEEDS 200 FEET, AND TWO TURN ARROWS ARE REQUIRED.

NOT TO SCALE



CITY of WESTMINSTER
 4800 WEST 92ND AVENUE
 WESTMINSTER, COLO. 80031

CROSSWALKS AND STOP
 BAR DETAIL – DUAL LEFT

DATE: JUNE 2019

T26

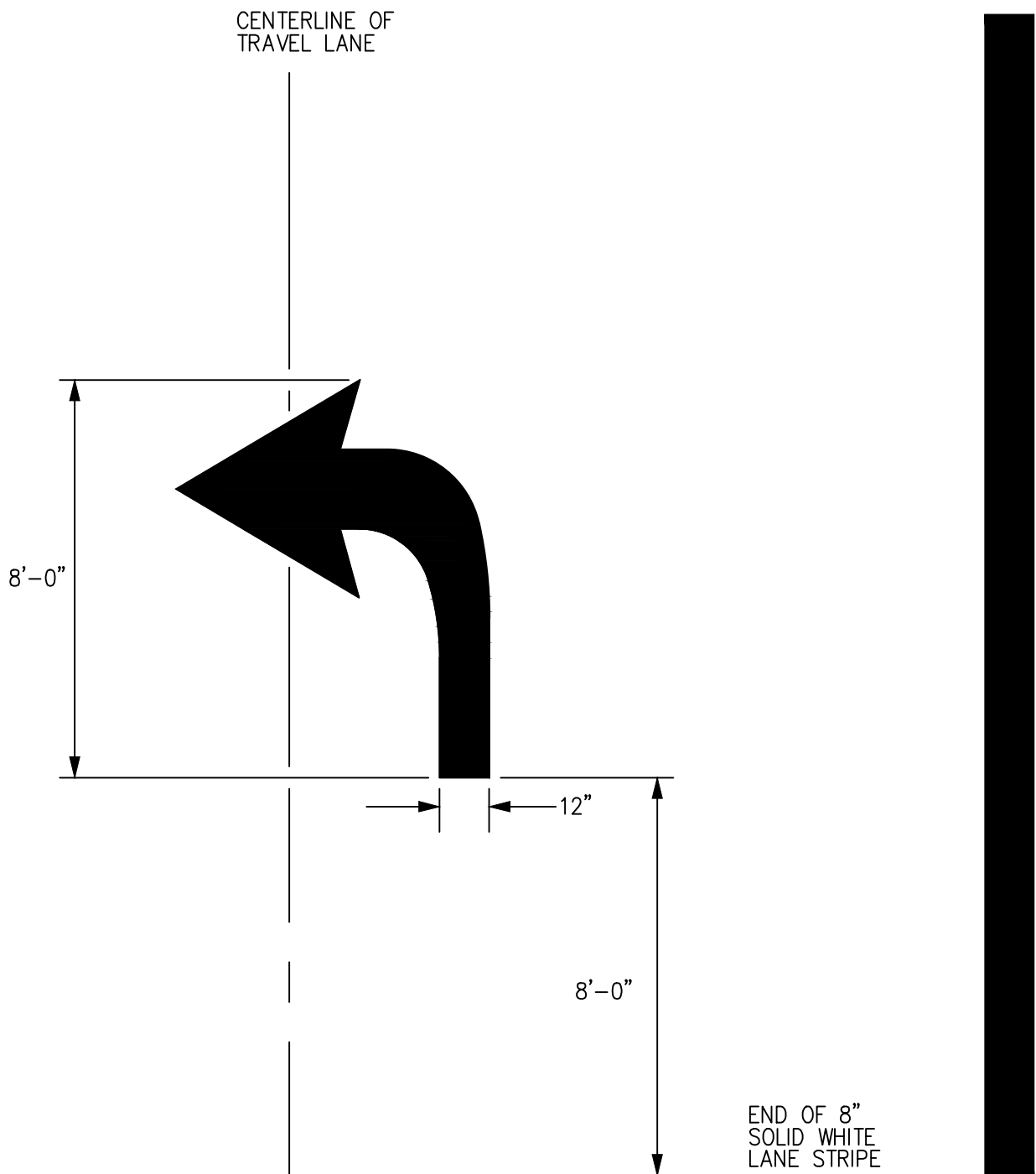

NOTES

1. IF TURN LANE EXCEEDS 200 LINEAR FEET, THEN ADDITIONAL ARROW IS REQUIRED AND PLACED 30 LF FROM STOP BAR.

NOT TO SCALE



CITY of WESTMINSTER
 4800 WEST 92ND AVENUE
 WESTMINSTER, COLO. 80031

TURN ARROW
 DETAIL

DATE: JUNE 2019

T27

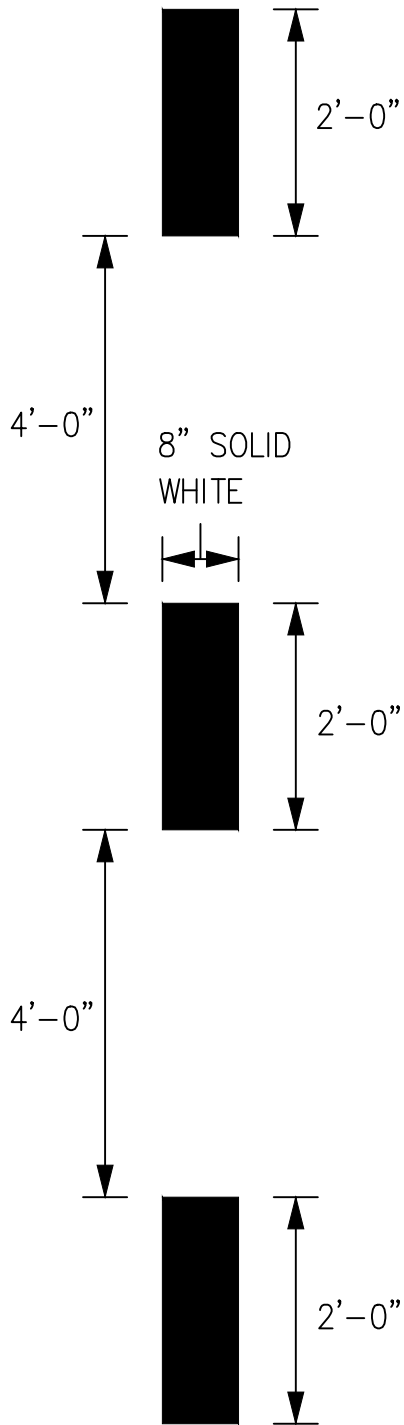

ROADWAYS 35 MPH OR LESS

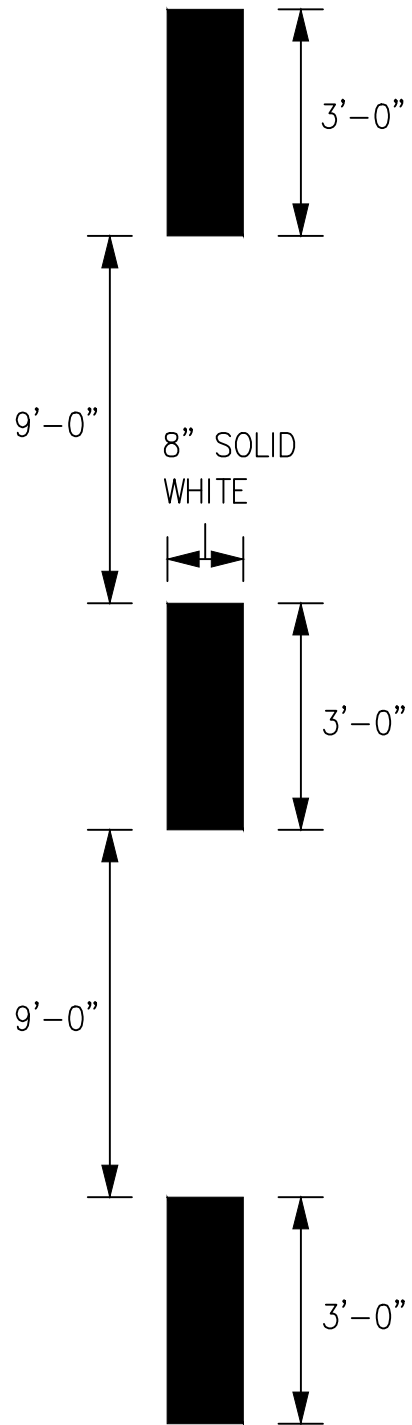

ROADWAYS GREATER THAN 35 MPH

NOT TO SCALE



CITY of WESTMINSTER
 4800 WEST 92ND AVENUE
 WESTMINSTER, COLO. 80031

INTERSECTION LANE USE
 CONTROL PVMT. MARKING

DATE: JUNE 2019

T28

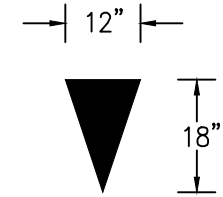
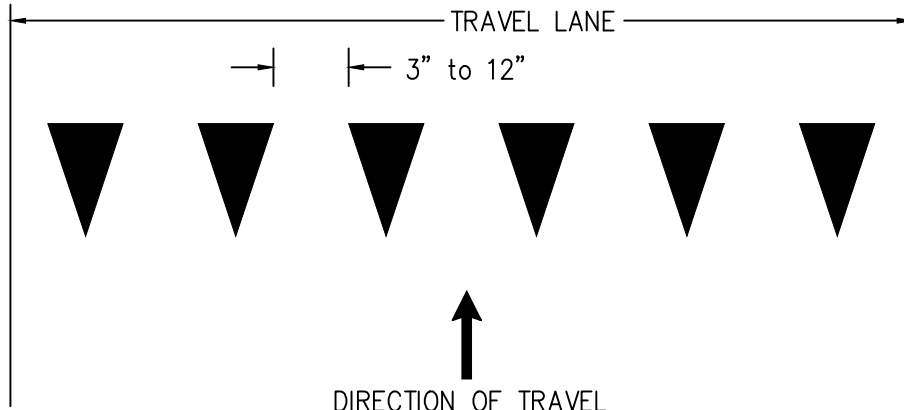

MINIMUM DIMENSIONS

DIRECTION OF TRAVEL

LOCAL ROADWAYS

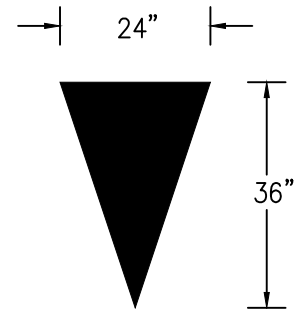
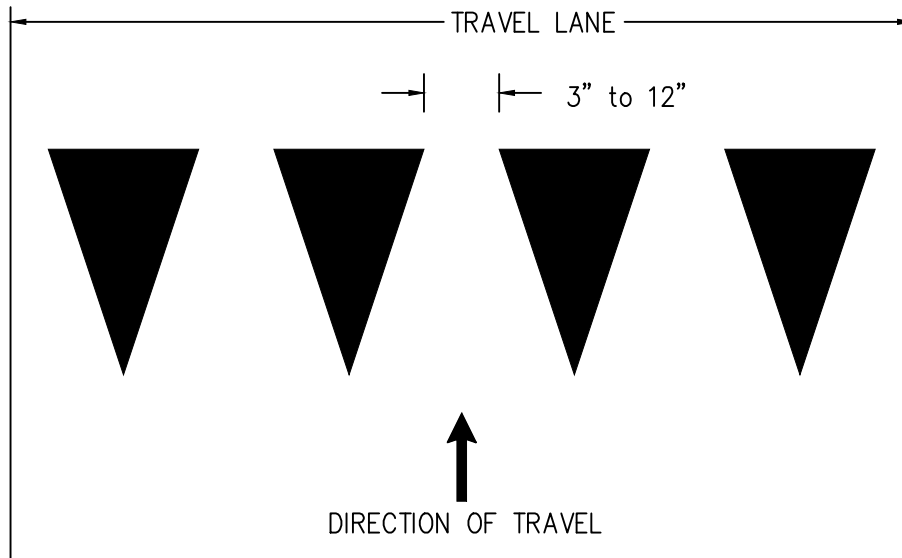

MAXIMUM DIMENSIONS

DIRECTION OF TRAVEL

ARTERIAL OR COLLECTOR ROADWAYS

NOT TO SCALE



CITY of WESTMINSTER
 4800 WEST 92ND AVENUE
 WESTMINSTER, COLO. 80031

YIELD LINES

DATE: JUNE 2019

T29

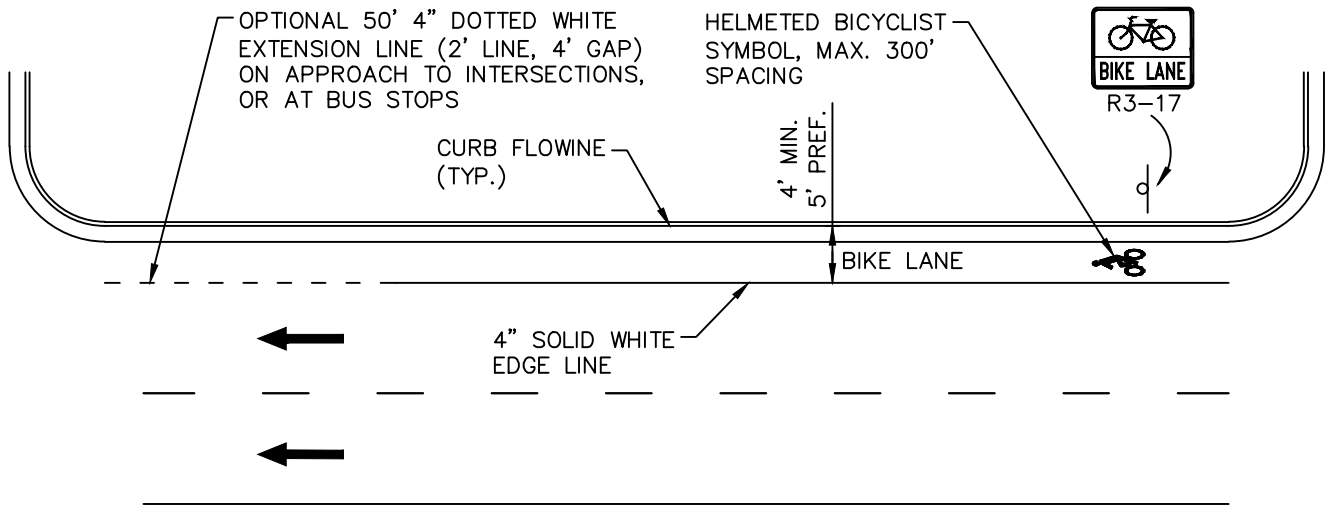

BICYCLE LANE PAVEMENT MARKINGS

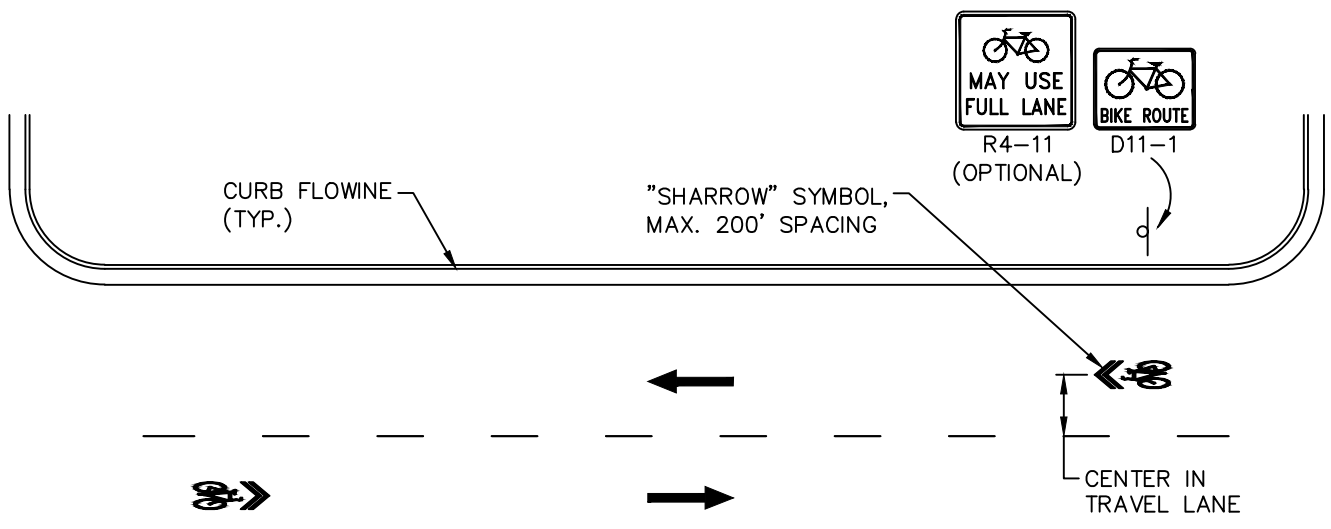

SHARED LANE PAVEMENT MARKINGS

NOTES:

1. ADDITIONAL WIDTH FOR BIKE LANES MAY BE REQUIRED AT THE CITY ENGINEER'S DISCRETION.
2. BICYCLE LANE MARKINGS SHALL BE ACCORDING TO THE M.U.T.C.D.

NOT TO SCALE



CITY of WESTMINSTER
 4800 WEST 92ND AVENUE
 WESTMINSTER, COLO. 80031

BICYCLE LANE PAVEMENT MARKINGS

DATE: JUNE 2019

T30

OPTIONAL 4" DOTTED WHITE
EXTENSION LINES
(2' LINE, 4' GAP) AT MINOR
STREETS AND DRIVEWAYS

HELMETED BICYCLIST
SYMBOL, MAX. 300'
SPACING

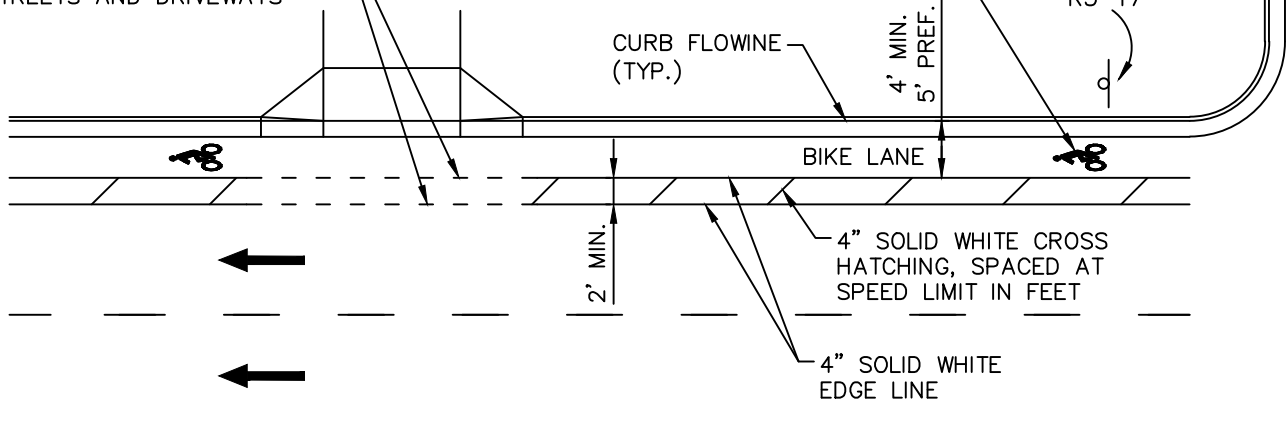

BUFFERED BICYCLE LANE
PAVEMENT MARKINGS

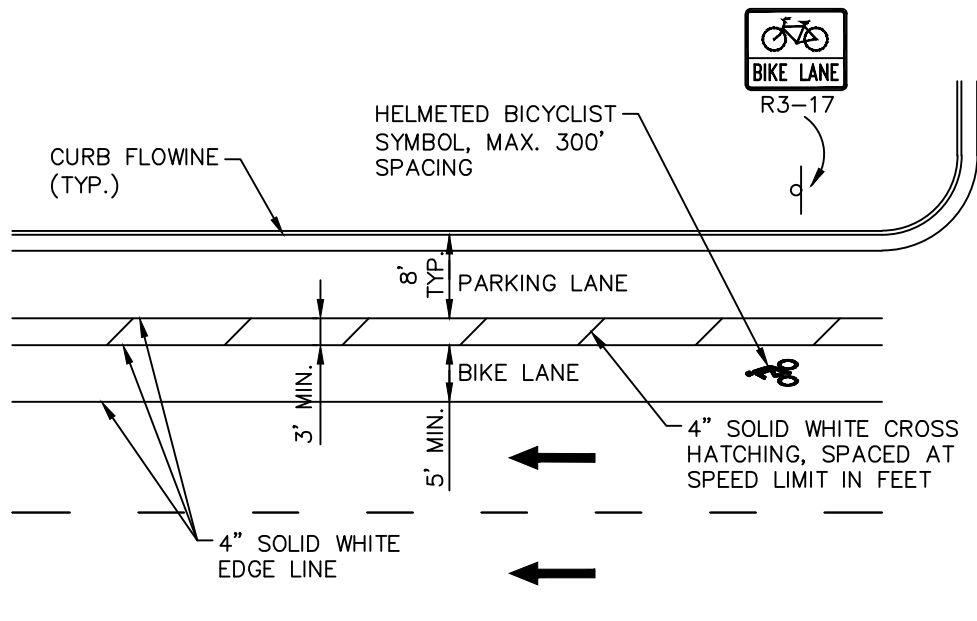

BUFFERED BICYCLE LANE AND
PARKING LANE PAVEMENT
MARKINGS

NOTES:

1. ADDITIONAL WIDTH FOR BIKE LANES MAY BE REQUIRED AT THE CITY ENGINEER'S DISCRETION.
2. BICYCLE LANE MARKINGS SHALL BE ACCORDING TO THE M.U.T.C.D.

NOT TO SCALE



CITY of WESTMINSTER
4800 WEST 92ND AVENUE
WESTMINSTER, COLO. 80031

**BICYCLE LANE
PAVEMENT MARKINGS**

DATE: JUNE 2019

T31

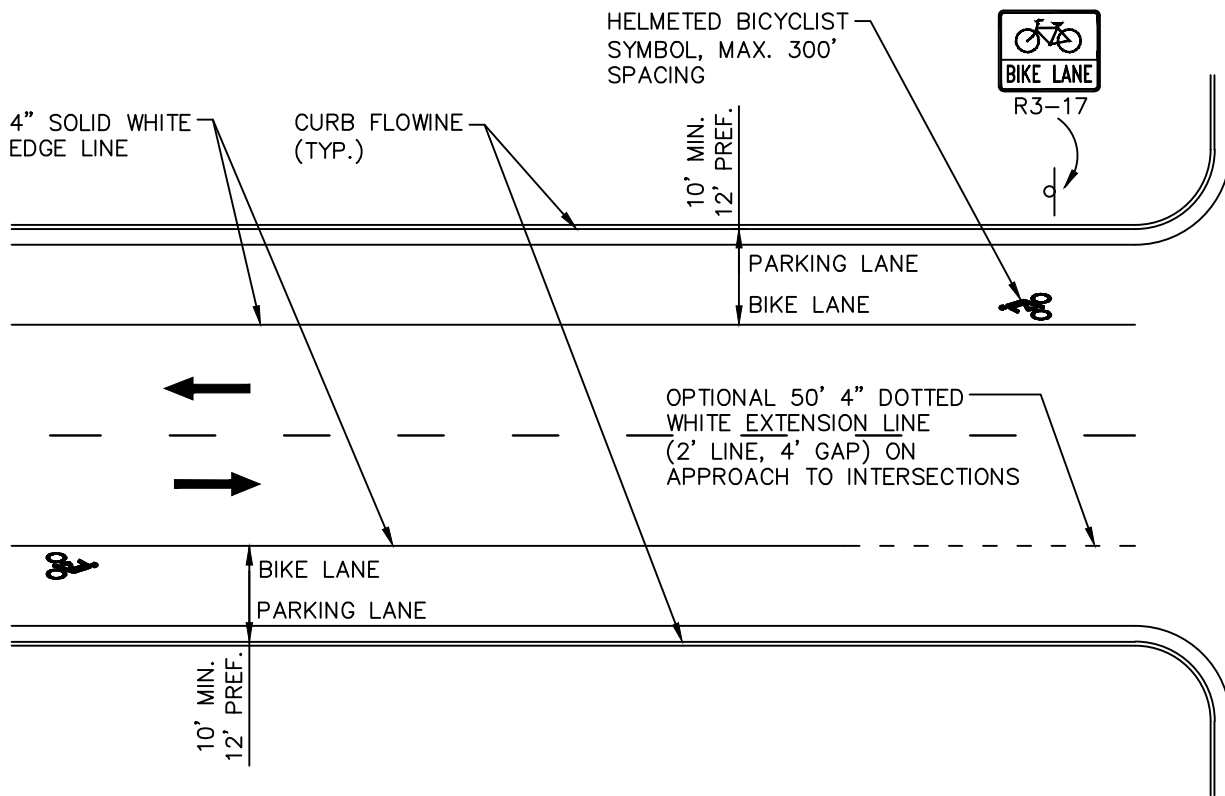

SHARED BICYCLE AND PARKING LANES
(RESIDENTIAL AREAS ONLY)

NOTES:

1. SHARED BICYCLE AND PARKING LANES SHALL BE USED ONLY IN RESIDENTIAL AREAS WHERE PARKING TURNOVER IS ANTICIPATED TO BE LOW AND SHALL BE APPROVED BY THE CITY TRAFFIC ENGINEER.
2. ADDITIONAL WIDTH FOR BIKE LANES MAY BE REQUIRED AT THE CITY ENGINEER'S DISCRETION.
3. BICYCLE LANE MARKINGS SHALL BE ACCORDING TO THE M.U.T.C.D.

NOT TO SCALE



CITY of WESTMINSTER
4800 WEST 92ND AVENUE
WESTMINSTER, COLO. 80031

**BICYCLE LANE
PAVEMENT MARKINGS**

DATE: JUNE 2019

T32

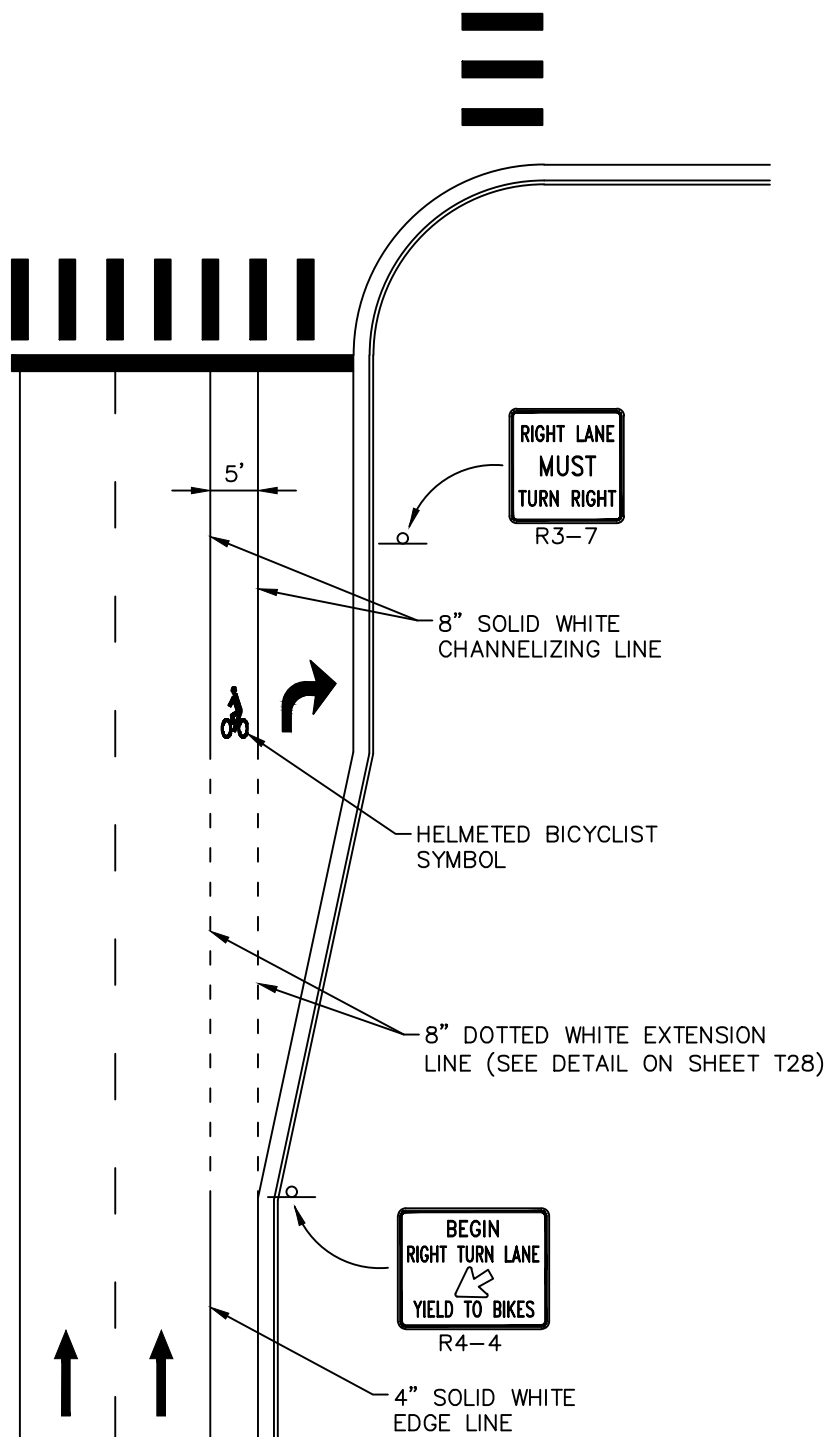

BICYCLE LANE AT SEPARATE
RIGHT TURN LANE

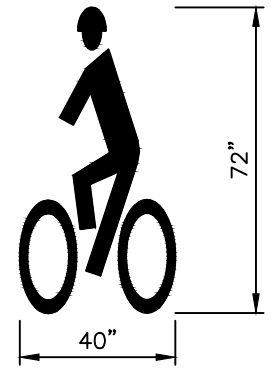

HELMETED BICYCLIST
SYMBOL

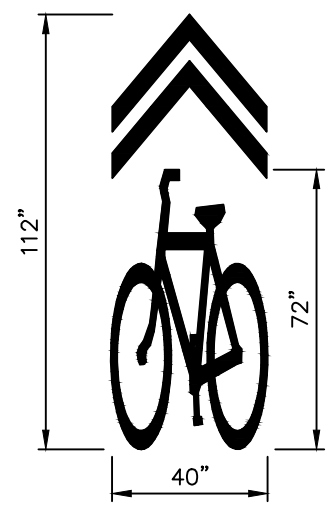

"SHARROW" SHARED
LANE SYMBOL

NOTES:

BICYCLE LANE MARKINGS SHALL BE ACCORDING TO THE M.U.T.C.D.

NOT TO SCALE



CITY of WESTMINSTER
4800 WEST 92ND AVENUE
WESTMINSTER, COLO. 80031

BICYCLE LANE
PAVEMENT MARKINGS

DATE: JUNE 2019

T33

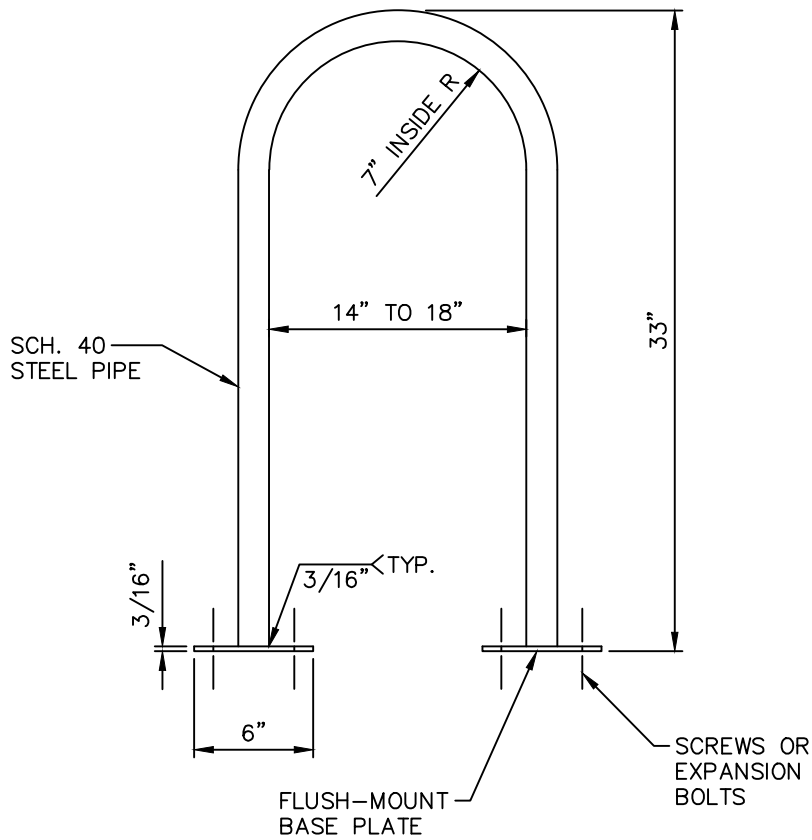

ELEVATION VIEW

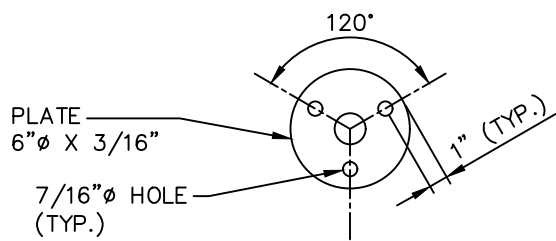

BASE PLATE DETAIL

NOTES:

1. PIPE SHALL BE:
 -MINIMUM 1-1/4" SCHEDULE 40 STEEL PIPE (1-5/8" OUTSIDE DIAMETER)
 -MAXIMUM 1-1/2" SCHEDULE 40 STEEL PIPE (2" OUTSIDE DIAMETER)
2. U-PIPE SHALL BE SOLID ONE-PIECE CONSTRUCTION WITH CONTINUOUS BEND AND LEGS 14" TO 18" APART.
3. U-PIPE AND BASE PLATE PIPE SHALL BE GALVANIZED WITH COLOR POWDER COAT FINISH. COLOR SHALL BE FEDERAL STANDARD 595C FS 14056 (FEDERAL GREEN).
4. THE RACK SHALL BE FLUSH MOUNTED WITH WELDED BASE PLATES. ANCHOR TO CONCRETE WITH HIDDEN OR VANDAL-RESISTANT FASTENERS (SCREWS OR EXPANSION BOLTS).

NOT TO SCALE



CITY of WESTMINSTER
 4800 WEST 92ND AVENUE
 WESTMINSTER, COLO. 80031

INVERTED "U"
 BICYCLE RACKS

DATE: JUNE 2019

T34

CONCRETE PAD NOTES:

1. EXPOSED CONCRETE SURFACE SHALL BE BROOM FINISHED.
2. PAD SIZE MAY VARY AS DIRECTED BY THE CITY ENGINEER.
3. PAD SHALL BE CONSTRUCTED WITH CLASS B OR CLASS D CONCRETE.
4. CONCRETE PAD SURFACE SHALL BE SLOPED AT 2% TO DRAIN.

DIMENSIONS:

- * 3'-4" MINIMUM WHEN INSTALLED PERPENDICULAR TO A WALL OR CURB
- ** 3' MINIMUM WHEN INSTALLED PARALLEL TO A WALL OR CURB, 5' MINIMUM SEPARATION FROM CURB FACE WHEN INSTALLED ADJACENT TO A CURB WITH HEAD-IN PARKING
- *** 10' MINIMUM IF MORE THAN TWO U-RACKS IN A SERIES

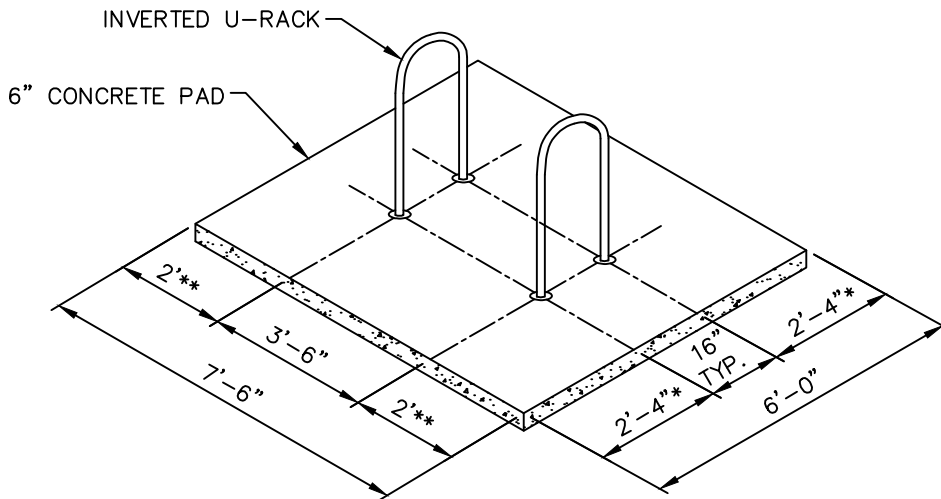

SIDE-BY-SIDE RACKS

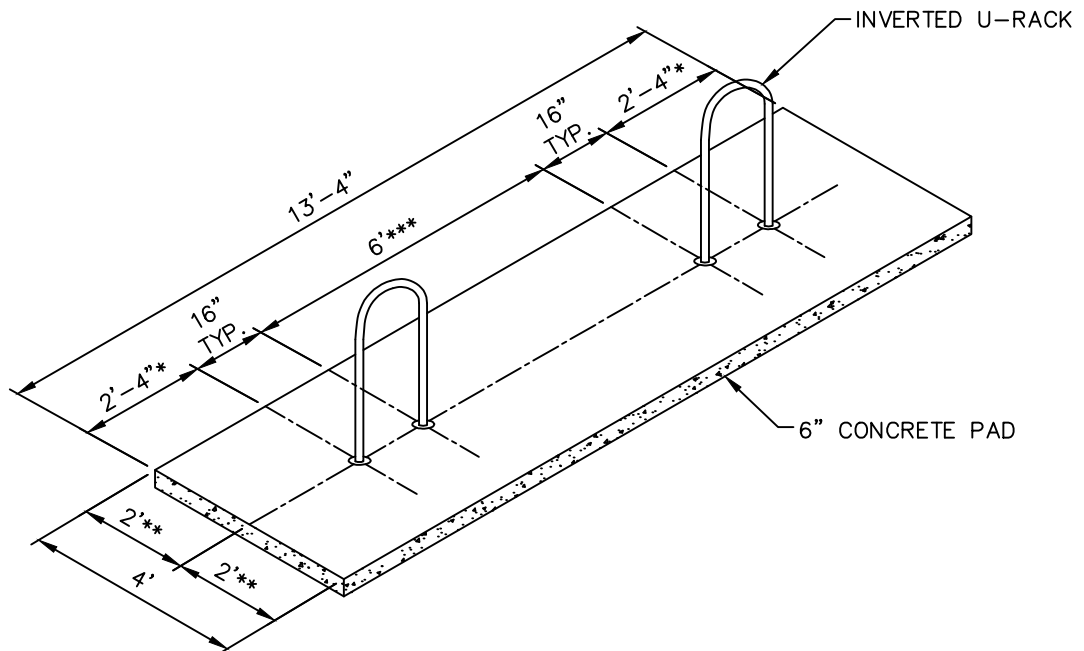

END-TO-END RACKS

NOT TO SCALE



CITY of WESTMINSTER
 4800 WEST 92ND AVENUE
 WESTMINSTER, COLO. 80031

INVERTED "U"
 BICYCLE RACKS

DATE: JUNE 2019

T35